



# Instruction Manual for SelectSun 20K Photovoltaic String Inverter

## Installation • Operation • Service

Doc. No. | 982055  
Version | 01  
Date | 2018-03  
Language | English

## Copyright

© Selectronic Australia Pty Ltd. All rights reserved.

This manual and the information included therein are the property of Selectronic Australia Pty Ltd.

No part of this manual is to be reproduced or copied without the express written permission of Selectronic Australia Pty Ltd. Any unauthorized use of this manual is strictly forbidden.

Changes may be made to specifications, descriptions and delivery information.

## Publisher

Selectronic Australia Pty Ltd | Suite 5, 20 Fletcher Road | Chirnside Park, Victoria, 3116 | Australia

## Trademarks

All trademarks or registered trademarks are the property of their respective owners.

## Disclaimer and Limitation of Liability

Selectronic Australia Pty Ltd assumes no liability in the event of damage as a consequence of the failure to observe the warning instructions in these operating instructions or of improper usage.

The operating, maintenance and safety instructions are to be read carefully prior to installation and commissioning.

The installation, commissioning and safety-related check must be undertaken by a qualified electrician.

Error-free and safe operation of the device requires proper and professional transport, storage, assembly, and installation, as well as careful operation and maintenance.

Only accessories and spare parts approved by the manufacturer are permitted.

Technical modifications to the device are not permitted.

Adherence to the safety regulations and provisions of the country in which the inverter will be used are to be observed.

The environmental conditions, technical calculation data and connection conditions of the grid operator given in the product documentation must be upheld.

The technical data, calculation, connection and installation conditions are to be derived from the product documentation and must be observed under all circumstances.

No liability is assumed for damages in connection with force majeure and disaster situations.

## Table of Contents

Copyright.....	2
Publisher .....	2
Trademarks .....	2
Disclaimer and Limitation of Liability.....	2
Table of Contents.....	3
<b>1 About this Instruction Manual</b> .....	<b>6</b>
1.1 Symbols and Markup .....	6
1.2 Warning Notices .....	6
1.2.1 Layout of a Warning Notice.....	6
1.2.2 Categories of Warning Notices .....	6
1.3 Information .....	7
<b>2 Safety Information</b> .....	<b>8</b>
2.1 Intended Use .....	8
2.2 Qualification of Personnel .....	8
2.3 Dangers Arising from Misuse .....	9
2.4 Protection against Contact with Electrical Parts .....	10
2.5 Protection against Contact with Hot Parts .....	10
2.6 Protection during Handling and Assembly .....	11
2.7 Please Note Before Starting Up .....	11
2.8 Additional Symbols and Warning Notices on the Inverter.....	12
<b>3 Description of Device</b> .....	<b>13</b>
3.1 Infrastructure Requirements.....	13
3.2 Features of SelectSun 20K .....	13
3.3 External Dimensions .....	14
3.4 Block Diagram .....	14
3.4.1 SelectSun 20K .....	14
3.5 DC Connection .....	15
3.6 Internal Data Logger .....	15
<b>4 Installation</b> .....	<b>16</b>
4.1 Assembly Site Requirements.....	16
4.2 Transport.....	17
4.3 Storage.....	17
4.4 Checking scope of delivery .....	18
4.5 Unpacking the Device .....	18
4.6 Installation .....	19
4.7 Device connectors.....	20
4.8 Grounding.....	21
4.9 Residual Current Protection .....	21
4.10 Power Connection .....	21
4.11 Power Supply Line.....	23
4.11.1 Fitting of supplied power plug .....	23
4.12 Grid Line Impedance .....	25
4.13 DC connection PV generator.....	26
4.13.1 DC-Connection .....	27

4.13.2	Connect PHOENIX CONTACT connector (SUNCLIX).....	28
4.13.2.1	Connect cable.....	28
4.13.2.2	Disconnect connector.....	29
4.13.2.3	Remove cable.....	29
4.14	Interface Port RS485.....	30
4.15	Ethernet Interface Connection.....	31
<b>5</b>	<b>Commissioning</b> .....	<b>33</b>
5.1	Turning on the Device.....	33
5.2	Setting the Country Code and the Menu Language.....	34
5.2.1	Set Country Code/Grid Guideline.....	34
5.2.2	Accepting the Country Code.....	35
5.3	Device Start.....	35
5.4	Control Panel.....	36
5.5	Basic Screen.....	37
5.6	Graphical Display.....	37
5.7	Energy Yield Data Display.....	38
5.8	Standardized Energy Yield Data Display.....	38
5.9	Input of Standardized Data.....	38
5.10	Menu Structure.....	40
<b>6</b>	<b>Configuration</b> .....	<b>41</b>
6.1	Changing the Menu Language.....	41
6.2	Limitation of the Power Output.....	41
6.3	Monitoring Portal.....	42
6.4	PC Configuration Tool.....	42
6.5	Communication via Ethernet.....	43
6.5.1	Automatic Setting via DHCP.....	43
6.5.2	Manual Setting.....	43
6.6	Communication via RS485.....	44
6.7	Portal Monitoring.....	44
6.8	Sending Config.....	45
6.9	Portal Test Function.....	45
<b>7</b>	<b>Troubleshooting</b> .....	<b>46</b>
7.1	Self-Test – Error Message.....	46
7.2	Transient Failure.....	46
7.3	Faults.....	46
7.4	Fault Acknowledgement.....	46
7.5	List of Error Messages.....	47
<b>8</b>	<b>Options</b> .....	<b>53</b>
8.1	Irradiation and Temperature Sensor.....	53
8.1.1	Inverter Sensor Interface.....	53
8.1.2	Sensor Type Si-13TC-T-K Cable.....	53
8.1.3	Assembling of the Sensor Plug.....	54
8.1.4	Connection of the Sensor at the Solar Inverter.....	54
8.1.5	Configuration.....	55
8.2	External Turn Off Signal.....	56
8.2.1	Overview.....	56
8.2.2	Function.....	56

---

8.2.3	Connections of the External Stop Signal (DRM 0).....	57
8.2.4	Configuration of the External Stop Signal (DRM 0).....	58
8.2.5	Attach the DRM 0 Sticker.....	58
<b>9</b>	<b>Maintenance</b>	<b>59</b>
9.1	Maintain the Inverter .....	59
<b>10</b>	<b>Decommissioning</b>	<b>60</b>
10.1	Remove Inverter .....	60
10.2	Disposal .....	61
<b>11</b>	<b>Technical data</b>	<b>62</b>
11.1	Inverter.....	62
<b>12</b>	<b>Certificates</b>	<b>64</b>
<b>13</b>	<b>Contact</b>	<b>65</b>

# 1 About this Instruction Manual

These operating instructions form part of the product.

- ⇒ Read the Instruction Manual carefully before installing and using the product.
- ⇒ Keep the operating instructions readily available with the device for the entire service life of the product.
- ⇒ Provide all future users of the device access to the operating instructions.

## 1.1 Symbols and Markup

☑	Prerequisite
⇒	One-step instruction
1.	Multiple-step instruction
•	Bulleted list
<b>Highlighting</b>	Highlighting within a text
↪	Result

## 1.2 Warning Notices

### 1.2.1 Layout of a Warning Notice

**⚠ SIGNALWORD / WARNING INSTRUCTIONS CATEGORY**

**Type and source of danger**  
 Consequences if the warning is not observed  
 ⇒ Required action to avoid the risk

### 1.2.2 Categories of Warning Notices



**⚠ DANGER**

**Leads directly to death or serious personal injury if ignored.**  
 Follow the warnings to avoid death or serious injury!



**⚠ WARNING**

**May result in death or serious personal injury if ignored.**  
 Follow the warnings to avoid serious injuries!



## ⚠ CAUTION

**May cause minor personal injury if ignored.**  
Follow the warnings to avoid injury!

## NOTICE

**Can lead to property damage if ignored.**  
Follow the warnings to avoid damage or destruction of the product!



This symbol represent important notes concerning potential harm to people, this unit, or associated equipment.

## 1.3 Information



### Note:

A **notice** describes information which is important for the optimum and cost-effective operation of the equipment.

## 2 Safety Information

### 2.1 Intended Use

The SelectSun 20K inverter, also referred to in these operating instructions as the inverter, is a solar inverter, which transforms the direct current generated by the PV generator (photovoltaic modules) into alternating current and feeds this to the public power supply network.

The inverter is manufactured according to the rules and current state of technology and takes into account the valid EU, IEC and UL guidelines respectively.

The inverter fulfils the requirements according to protection class IP 65 / NEMA 4 and can be used indoors and outdoors.

Any other use is not considered to be a designated use. The manufacturer accepts no liability for damages resulting from this.

### 2.2 Qualification of Personnel

Target group for these instructions are professionals who can assess the assigned tasks due to their professional training, knowledge and experience as well as knowledge of the relevant provisions and recognize possible dangers.

Electrical work must only be carried out by qualified electricians.

Only suitably trained and qualified personnel are allowed to work on this inverter. Personnel are regarded as being qualified if they are sufficiently familiar with the assembly, installation, and operation of the product as well as with all warnings and safety measures set out in these operating instructions.



## 2.3 Dangers Arising from Misuse



### **⚠ DANGER**

#### **Danger to life from electric shock**

- ⇒ Device may only be installed and serviced by qualified specialist technical personnel.
- ⇒ Only class A modules according to IEC 61730 must be used.
- ⇒ The PV generator must be free of earth potential.
- ⇒ The PV generator must be designed in accordance with the technical data of the inverter.
- ⇒ Before connecting or disconnecting the DC plug always open DC switch.
- ⇒ Every power supply line must be equipped with an appropriate AC-disconnecting device.
- ⇒ A consumer must never be switched between an inverter and line protection switch.
- ⇒ Access to the shutdown mechanism must always be free.
- ⇒ Installation and commissioning must be carried out properly.



### **⚠ DANGER**

#### **Danger to life from electric shock**

**After the device has been switched off, the interior may still contain life-threatening voltage**

- ⇒ Do not open inverter.
- ⇒ Discharge time is at least 15 minutes.



### **⚠ DANGER**

#### **Danger to life from high discharge current**

- ⇒ It is essential to ensure an earthing connection has been established prior to connection to the supply current circuit.

## 2.4 Protection against Contact with Electrical Parts



### DANGER

#### **Danger to life, danger of injury due to high electrical voltage**

- ⇒ Installation of the inverter must only be carried out by trained specialist personnel. In addition, the installer must be accredited by the responsible utility company.
  - ⇒ General assembly and safety stipulations relating to working on high current facilities must be followed.
  - ⇒ Before switching on, a check must be made to ensure that the plugs are firmly in place (locked).
  - ⇒ Before plugging or unplugging the DC plug, always disconnect the connection to the PV generator.
  - ⇒ The feeder must be isolated and secured against being switched on again before working at the AC grid.
- 

## 2.5 Protection against Contact with Hot Parts



### CAUTION

#### **Danger of burns caused by hot surfaces on housings**

At an ambient temperature of 45 °C, the upper part of the housing as well as the refrigeration unit can reach a surface temperature of more than 75 °C.

- ⇒ Do not touch the housing surface near to heat sources.
  - ⇒ Allow the device to cool down for 15 minutes before touching the surface of the device.
-

## 2.6 Protection during Handling and Assembly

### **⚠ WARNING**

**Danger of injury during improper handling caused by crushing, shearing, cutting, striking, and lifting**











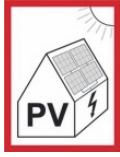

- ⇒ The weight of the inverter is 38.4 kg kg!
- ⇒ Follow the general setup and safety regulations for handling and assembly.
- ⇒ Use suitable assembly and transportation equipment.
- ⇒ Avoid trap and crush injuries by taking suitable precautions.
- ⇒ Only use suitable tools. Use special tools where this is prescribed.
- ⇒ Use lifting equipment and tools in a technically correct manner.
- ⇒ If necessary, use suitable protective equipment (for example, goggles, safety footwear, protective gloves).
- ⇒ Do not stand under hanging loads.
- ⇒ Remove any liquids onto the floor immediately to avoid the danger of slipping.

## 2.7 Please Note Before Starting Up

- In the event of installation in France, the device must be furnished with the warning sticker laid down by UTE C 15-712-1. The warning stickers are included in delivery.
- Problem-free and safe operation of the inverter is conditional upon due and specialised transportation, storage, assembly and installation as well as careful operation and maintenance.
- Only use accessories and spare parts approved by the manufacturer.
- Adherence must be ensured to the prescriptions and stipulations regarding safety of the country in which the inverter is to be used.
- The ambient conditions stated in the product documentation must be observed.
- Starting up is prohibited until the entire system meets the national regulations and safety rules regarding use.
- Operation is only permitted with adherence to the national EMC prescriptions for the present use case.
- The manufacturer of the equipment or machine is responsible for ensuring compliance with the thresholds required by the respective national regulations.
- For European countries, the EU Directive 2014/30/EU (EMC Directive) is to be observed when using the inverter.
- The technical data, connection and installation conditions are to be taken from the product documentation and must be observed under all circumstances.
- Switching off of the inverter must first be effected on the AC side via the circuit breaker. Then the inverter is to be switched off on the DC side, should maintenance work need to be carried out on the DC side.
- It is not necessary to switch off the inverter overnight, as the inverter switches off completely as soon as no DC voltage is present at the input. If no switch-off is effected, the inverter switches on automatically in the morning when the PV generator supplies sufficiently high voltage. This means that the maximum output is generated.

## 2.8 Additional Symbols and Warning Notices on the Inverter

	<p>Indication of PV system</p>
	<p>General warning sign</p>
	<p>Warning of electrical voltage</p>
	<p>Hot surface! The housing can get hot during use.</p>
	<p>This symbol advises that the user handbook must be read before the device is used.</p>
	<p>The inverter must be earthed before use.</p>
	<p>Before beginning of work switch unit free of voltage.</p>
<p>3N  </p> <p><b>Dual supply</b> <b>Multiple DC-supply</b></p>	<p>Warning of electrical voltage on DC and AC side. All solar strings on the DC side are at voltage.</p>
 <p><b>Discharge time longer than 15 min</b></p>	<p>Discharging time of the device longer than 15 minutes.</p>

# 3 Description of Device

## 3.1 Infrastructure Requirements

Additional required equipment	20K at the low voltage network
AC load break switch	necessary
Central grid protection device (VDE-AR-N 4105)	only for systems above 30 kVA required
Medium voltage transformer	not necessary

The following points are to be considered when planning the infrastructure:

- The 20K can only feed into the low-voltage grid.
- The 5-wire power supply line must be equipped with an appropriate AC disconnecting device.
- If the inverters are connected with the medium-voltage-grid, it must be operated with electrically isolating transformers.
- No other equipment may be connected between the transformer and inverters.

The following standards and technical regulations are also to be observed:

IEC 60364-4-41	Protection: Protection against electric shock
IEC 60364-4-43	Protection for safety - Protection against overcurrent
IEC 60364-5-52	Selection and erection of electrical equipment - wiring systems
BDEW	Technical Guidelines
VDN	Technical Guidelines

## 3.2 Features of SelectSun 20K

The SelectSun 20K is a transformer-less, three-phase solar inverter, which has a particularly high efficiency at any operating point. Heat is dissipated only by convection. An internal monitor prevents the device from exceeding the permissible ambient temperature. The inverter is designed such that the device does not have to be opened for assembly and connection work. All electrical connections are exclusively made with lockable connectors. The device features an integrated DC isolating switch according to EN 60947-3, which reduces the overall installation work. The inverter provides the usual communication interfaces RS485 and Ethernet. An illuminated graphical display shows the development of the feed-in power and other operating data in a clearly arranged manner. An 8-key control panel below the display also provides excellent control and navigation convenience. Based on its design in protection class IP 65, the inverter can be installed at an outside location as long as it is not in direct sunlight. An installation protected against sunlight under the solar modules is ideal here.

### 3.3 External Dimensions

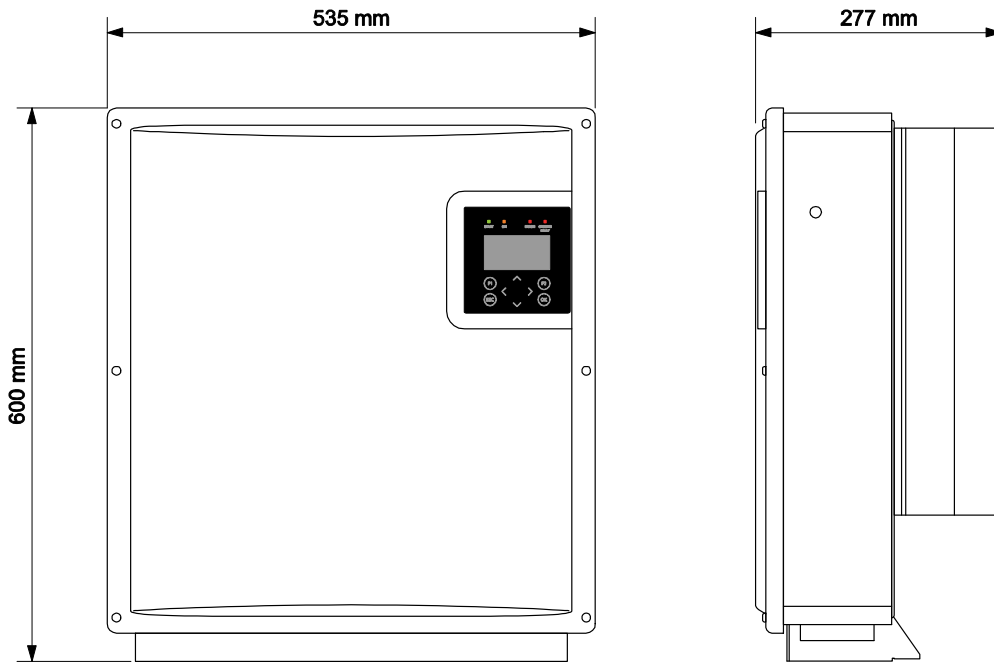

Fig. 1: External dimensions

### 3.4 Block Diagram

#### 3.4.1 SelectSun 20K

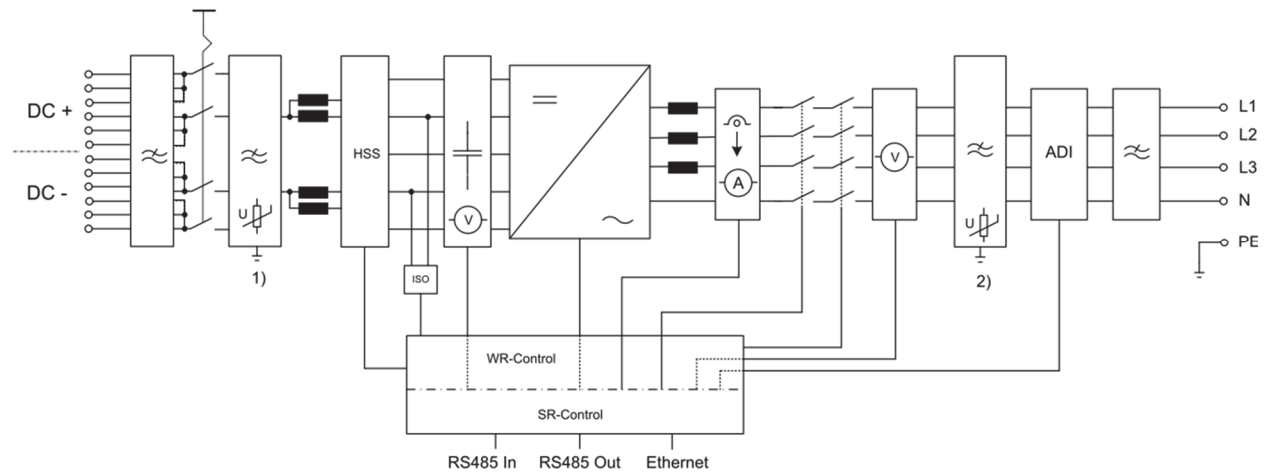

Fig. 2: Block diagram SelectSun 20K

1) DC overvoltage protection, type 3

2) AC overvoltage protection, type 3

## 3.5 DC Connection

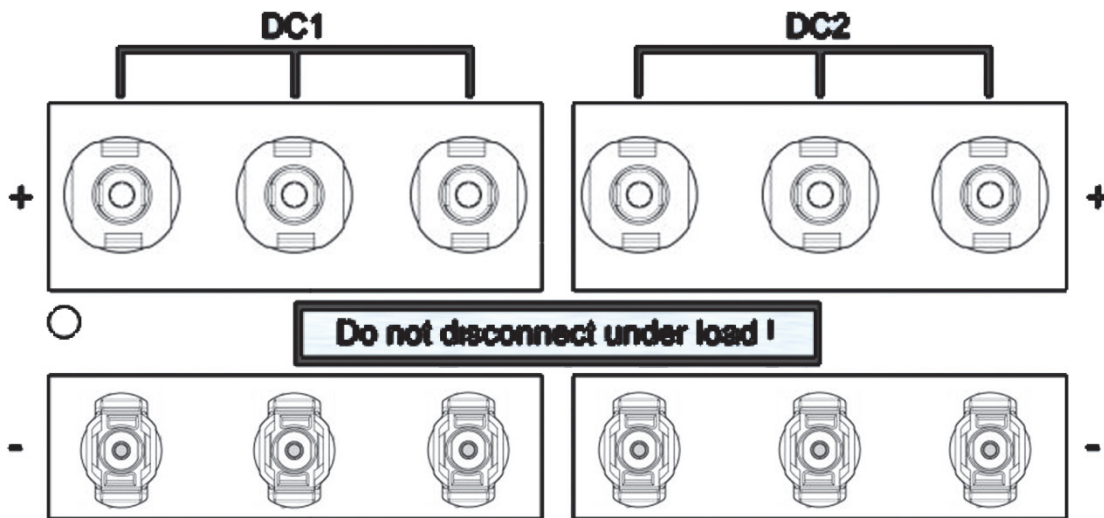

Fig. 3: Connection diagram

## 3.6 Internal Data Logger

The inverter features an internal data logger that allows measured values to be simultaneously recorded in the form of parameters. If the storage capacity is full, the oldest data is overwritten. With the default setting on delivery, the data logger logs 16 measuring channels.

Recording cycle	Storage time
1 minute	2.5 years
2 minutes	5 years
5 minutes	12.5 years
10 minutes	25 years

## 4 Installation

### 4.1 Assembly Site Requirements

#### DANGER



#### Danger to life due to fire or explosion

- ⇒ Do not install inverter in areas with risk of explosion.
- ⇒ Do not install inverter on flammable materials. Uphold fire protection class F30 according to DIN 4102 resp. the NFPA regulation
- ⇒ Do not install inverter in areas where easily flammable materials are stored.
- ⇒ Under no circumstances are the cooling fins of the heat sink to be covered.

#### WARNING



#### Danger of accident

- ⇒ When installing and servicing, unrestricted and safe access to the devices must be ensured.

The following requirements of the installation site must be upheld:

- Only vertical installation is permitted as otherwise the cooling of the device cannot be guaranteed (convection cooling).
- Do not subject the inverter to any direct sunlight.
- A fixed wall or a metal construction is necessary for installation. The weight of an inverter is 38.4 kg. Relevant construction regulations must be observed.
- The device is to be mounted at an appropriate distance from combustible materials.
- Installation in non-ventilated ended cabinets and enclosures is not allowed because the unit in operation emits heat.
- To allow for the heat dissipation required, keep the following minimum distances from the ceiling and wall as well as from neighbouring devices:



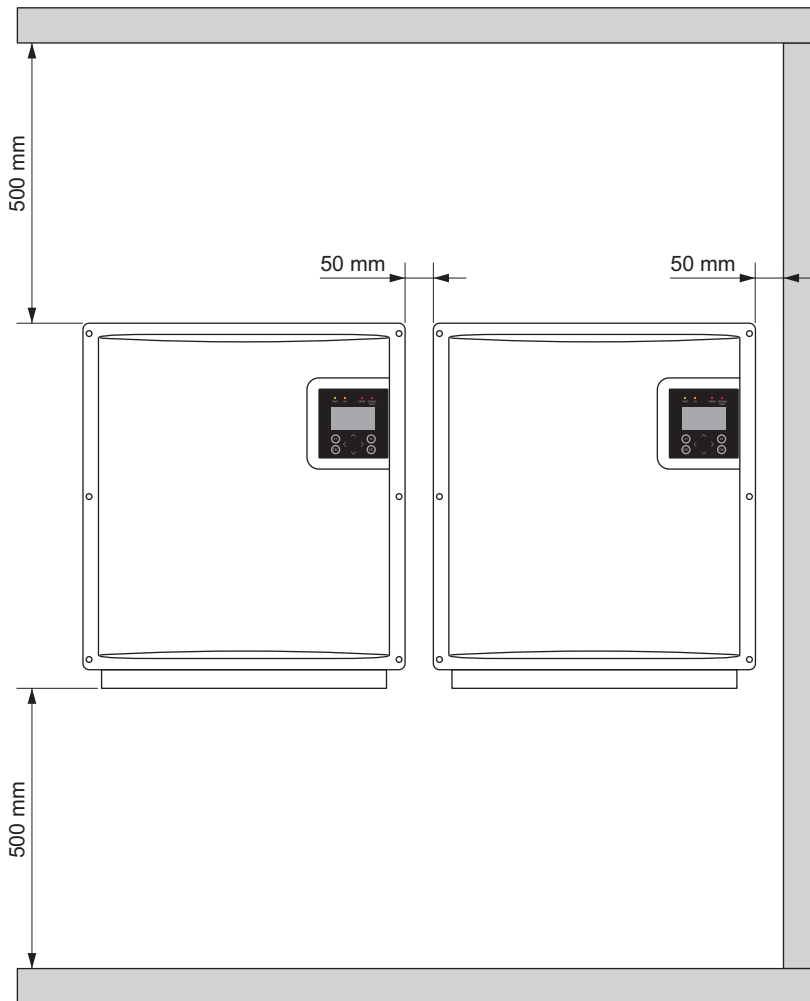

Fig. 4: Minimum distance

The device is best operated if the display is at eye level.

Protection class IP65 allows mounting in an outdoor area.

## 4.2 Transport

The devices must be transported under clean and dry conditions, if possible in their original packaging. The transport temperature must be between  $-25 - +70$  °C. Permissible variations in temperature may not exceed  $20$  °C ( $68$  °F) per hour.

## 4.3 Storage

The devices must be stored in clean and dry premises, if possible in their original packaging. The storage temperature must be in the range of  $-25 - +55$  °C. Permissible variations in temperature may not exceed  $20$  °C ( $68$  °F) per hour.

**Note:**



The inverter contains electrolytic capacitors which can be stored for no more than 1 year and at a storage temperature of  $\leq 40\text{ °C}$  /  $\leq 104\text{ °F}$  while in a de-energized state. If the storage time has been exceeded, please contact Selectronic Australia Pty Ltd Service before connecting the inverter to your system!

## 4.4 Checking scope of delivery

The scope of delivery includes:

- Solar Inverter SelectSun 20K
- Wall-mounting bracket
- Supplement with the following content:
  - 1x 5-pin contact insert, IP67, VC-TFS5-PEA for grid connection
  - 1x adapter housing IP67 VC-K-T3-R (10-25) PLOMB for grid connection
  - 2x cross-recessed flat-head screw, M5x20 => for mechanically securing the device in the wall bracket
  - 1x warning label in according UTE C 15-712-1 for installing in France

The screws for attachment to the wall are not included.

The IP67 VC-K-T3-R (10-25) PLOMB adapter housing allows sealing.

## 4.5 Unpacking the Device

### NOTICE

**Exposure to moisture, dust, or debris while unmounted in a non-vertical orientation poses a risk of ingress**

⇒ Only unpack the device when it is to be installed. Failure to do so voids your warranty!

---

The inverters are heaviest at the top. They are therefore packed upside down to facilitate transport. You will therefore see the bottom side of the device (connectors) after having opened the package. Take the device at the two holding grips that are visible on the side and remove it from the packaging. When being unpacked, the device keeps the packaging grid locked in place on its housing. The packaging grid can be used to deposit the device on the floor. This prevents the cover from being damaged.

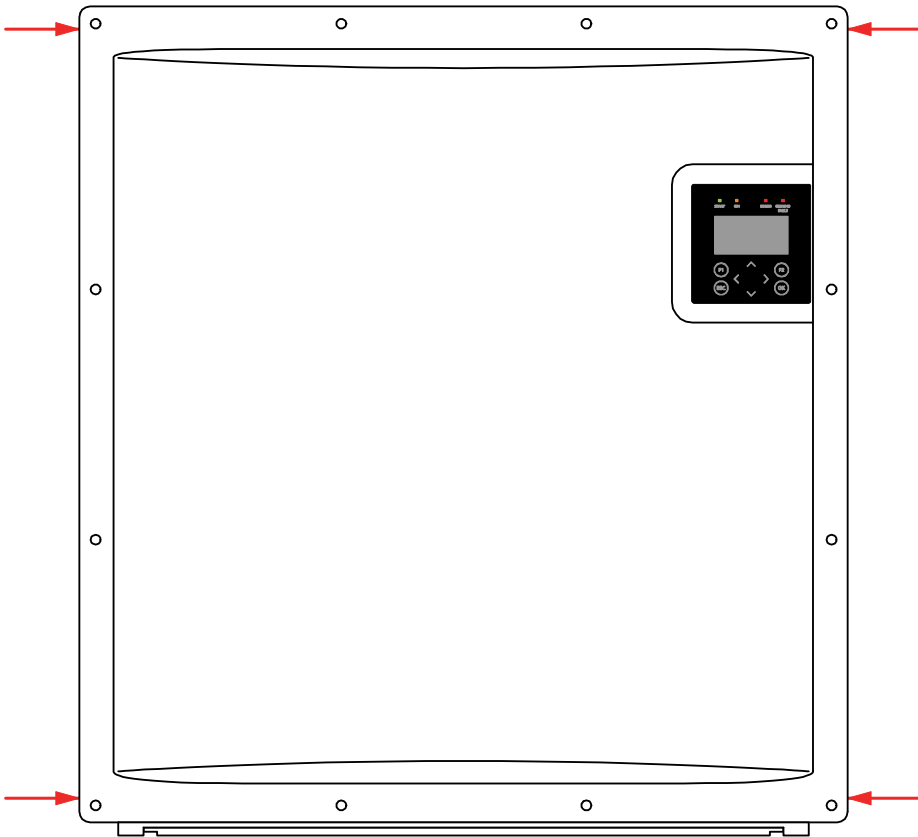

Fig. 5: Holding grip positions

## 4.6 Installation

Check the delivery before installation (see page 18).



### ⚠ CAUTION

#### Danger of injury

- ⇒ Do not use the cover to hold the device. Only use the four holding grips to move the device.

### NOTICE

#### Danger of damage to property

- ⇒ When designing the attachment of the wall-mounting plate, take the product weight of **38.4 kg** into account.
- ⇒ Do not open device. Opening the device voids the warranty.

The inverter is mounted using the wall-mounting plate which is included in the scope of delivery.

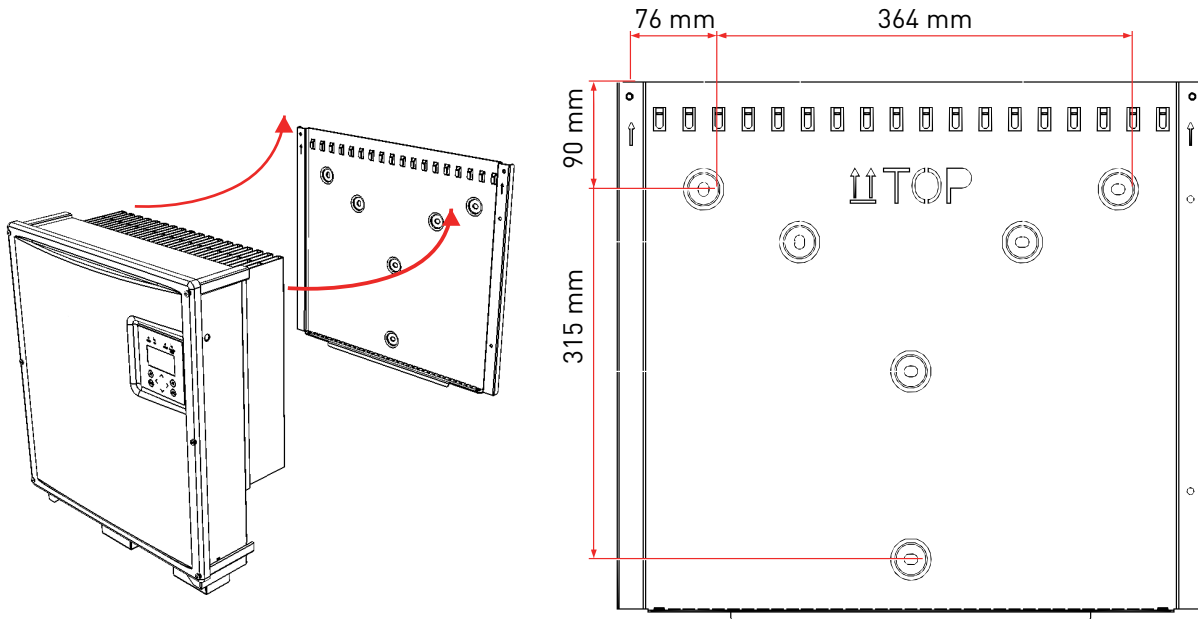

Fig. 6: Mounting the inverter

1. Use the wall bracket to mark the positions of the holes to be drilled.
2. Attach the mounting plate to the wall with the outer holes. The screws for attachment to the wall are not included. Screws with a diameter of 6 mm must be used.
3. Push the cooling fins of the inverter into the tabs of the wall mounting plate. Push the inverter upwards until it stops. Place the lower edge of the cooler onto the wall holder. Ensure that the rib profile is locked behind the nuts.
4. Secure the inverter in these nuts using the enclosed screws (M5x20). As an alternative, you can also use a padlock (shackle 4 mm in diameter) to protect the inverter against theft. The design of the wall bracket ensures that the inverter is automatically centered in this bracket.
5. In order to avoid adhesive residue on the display, remove the display protection immediately after installation.

## 4.7 Device connectors

The following figure shows the connectors of the inverter on its bottom side.

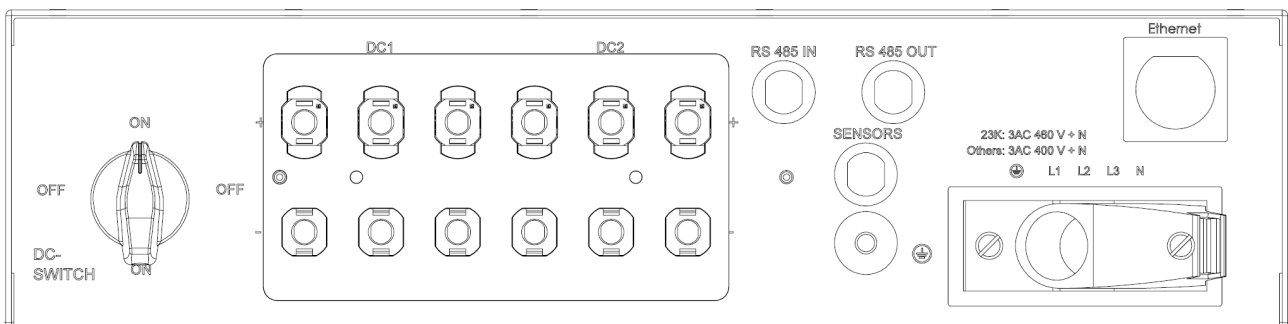

Fig. 7: Device connectors SelectSun 20K

The inverter is provided with the following connectors, as seen from left to right, top to bottom:

- 6 pair of PV generator connections
- RS485 connectors (IN and OUT)

- SENSOR (connection: Irradiation and temperature sensor, external shutdown signal)
- Ethernet interface port
- Power connection

## 4.8 Grounding

### DANGER



#### Danger to life from electric shock

- ⇒ The inverter must be earthed with the grounding bolt, otherwise a potential difference can build up, causing a risk of electric shock!

The inverter features a threaded bolt below the power supply port on the connection side for additional grounding. Grounding is intended to comply with the EMC requirements and to ensure optimum overvoltage protection. The ground wire cross-section must be bigger than the cross-section of the power supply line. In addition, ensure that the ground wire is placed as far away from and not directly in parallel to the power supply line.

**The maximum permissible torque for this screw is 10 Nm / 7 ft lbs.**

## 4.9 Residual Current Protection

### Note:



The photovoltaic power supply inverters without transformers meet the fault protection requirements according to IEC 60364-7-712 and CEI 64-8/7 can be operated with a type A residual-current circuit breaker.

The rated leakage current should be at least 300 mA per inverter.

## 4.10 Power Connection

### DANGER



#### Risk of electric shock and fire caused by high discharge current

- ⇒ Before connecting the device to the supply circuit, establish a ground - connection by means of the labelled ground stud!

**Note:**



To ensure the IP65 protection class, only use the male and female connectors provided and connect them according to the connector manufacturer's mounting instructions. To prevent any penetration of moisture and dirt, unused inputs and outputs must be properly closed. Failure to do so could void your warranty!

The following mains systems are allowed:

- TN-C-Net
- TN-C-S-Net
- TN-S-Net

The connection to the power supply must be via a 5-wire line. For safety reasons, the PE protective conductor must always be connected.

The power supply line must be equipped with an appropriate line protection. More information regarding the power connection you will find in the Technical Data, page 62.

Always observe the following standards:

IEC 60364-4-41	Protective measures: protection against electric shock
IEC 60364-4-43	Protection for safety: protection against overcurrent
IEC 60364-5-52	Low-voltage electrical installations: selection and erection of electrical equipment

The respectively national standards are to be upheld.

The following specifications of the local grid operator are to be observed:

- Pertinent technical and special regulations
- Installation approval must be in place
- Check the line voltage. It must be within the technical data for that device. If the line voltage is higher, contact your local network operator.
- The AC side must not be measured by inserting test probes into the AC plug, because this will damage the plug contacts.

**Note:**



When using wire end ferrules with isolating collar, make sure you do not introduce the insulation of the wire end ferrule into the clamping area of the terminal.

## 4.11 Power Supply Line

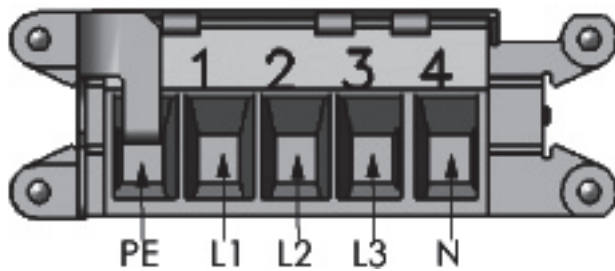

Fig. 8: Power Connection

Select the cross-section of the power supply line such that line losses are as low as possible. However, observe the following points:

- the installer must select the cable material according to the operation mode (installation location and laying type) and the national regulations.
- Due to the construction, the recommended feed line for all cross-sections is a fine wire.
- Copper wires must be used.
- Rigid wires are not recommended for the use of 16 mm<sup>2</sup> cables.
- The wires are to be installed in the correct position in order to minimise lateral forces on the net connection. The lateral forces must not exceed 250 N.
- The seal is run through a hole in the screw (below the screw head of the adapter housing) and the opening provided and attached to the housing of the device.

The following table shows the maximum wire lengths upon use of a SelectSun 20K depending on the cable cross section with a voltage drop below 1 %:

Line cross section	6.0 mm <sup>2</sup>	10.0 mm <sup>2</sup>	16.0 mm <sup>2</sup>
Max. line length	30 m	50 m	70 m



### Note:

In order to ensure IP65 protection, the AC connection housing supplied must be used.

### 4.11.1 Fitting of supplied power plug

The cable fitting of the standard connector housing supplied allows 5 x 6 mm<sup>2</sup> to 5 x 16 mm<sup>2</sup> cables to be connected. The maximum outside diameter of the power supply line may be 30.3 mm (e.g. Laptherm 145, 5 x 6 mm<sup>2</sup>).

1. Bend cable into position.
2. Strip the cable as shown in the illustration.

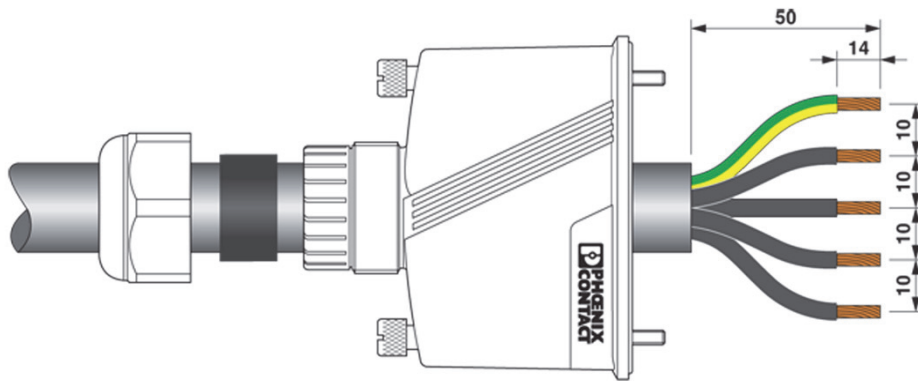

Fig. 9: Preparation of plug cable

3. Screw in plug.
4. Note torque specification according to illustration.

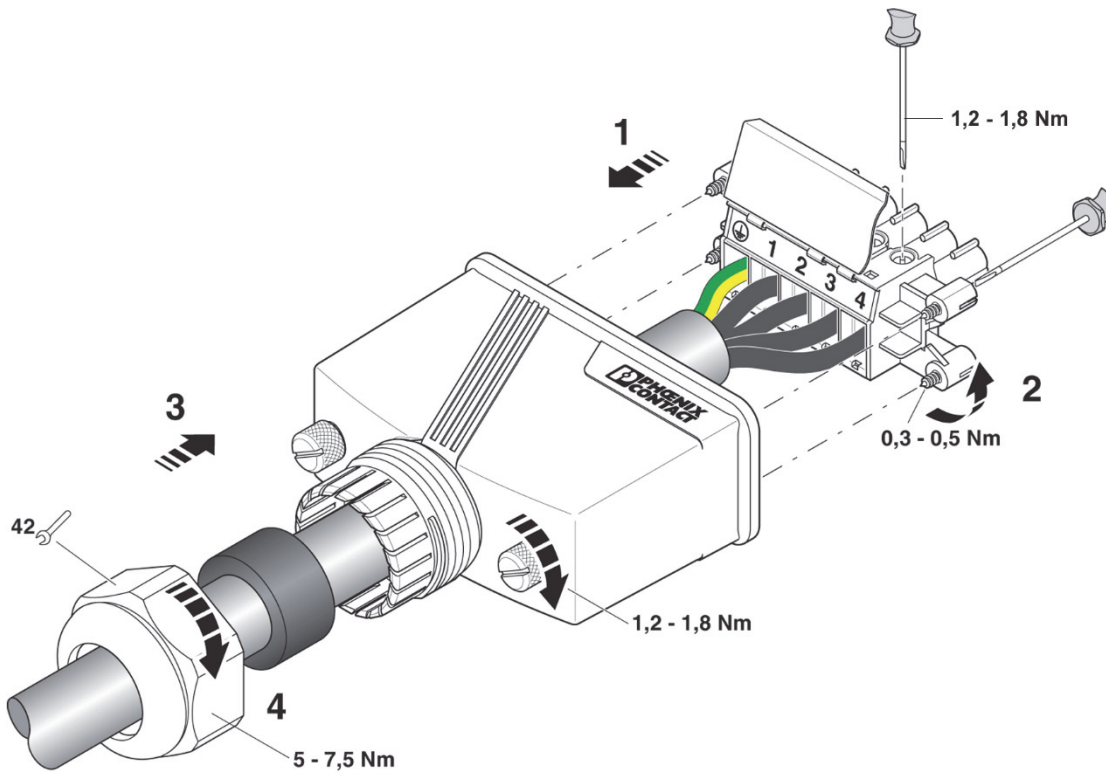

Fig. 10: Screw in plug

5. Determine diameter.
6. Seal connection.



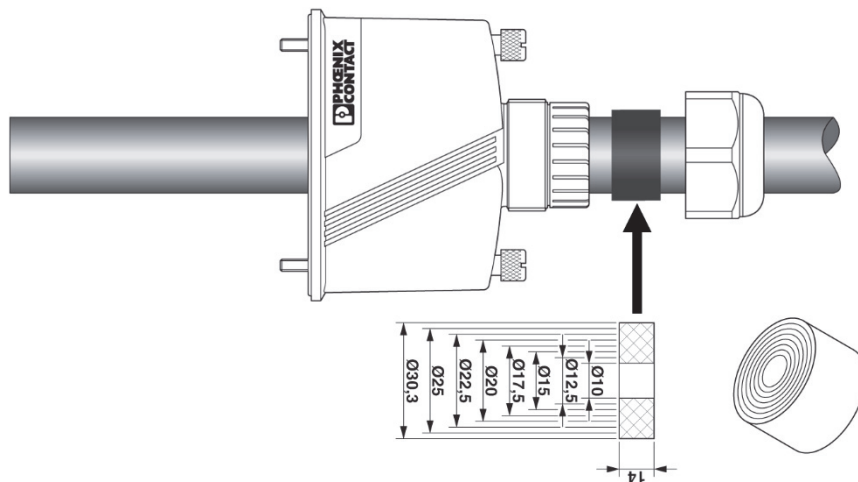

Fig. 11: Diameter

## 4.12 Grid Line Impedance

For better efficiency, large line cross-sections in single cables are increasingly used for power supply lines, especially if local conditions require long supply lines.

In large-scale plants, it is recommended as a best practice to locate the inverters in close proximity to the step-up transformer. If the inverters are located in a decentralized fashion, with long distances to the transformer, the higher AC cable inductance can lead to increasing line impedances. This can lead to voltage distortions and error messages with regards to:

- Grid overvoltage (long cable)
- Increased operating noise of the inverters (short cable)

To avoid these disadvantageous conditions, twisted lines should be used for power supply if possible. If laying of twisted lines is not possible, the following requirements must be met for single cores:

- Lay single cores next to each other.
- It is not allowed to lay single cores in closed, magnetically conducting materials (e.g., sheet steel pipe).
- If laid in open cable ducts, single cores should be laid such that the spacings between them are as small as possible.

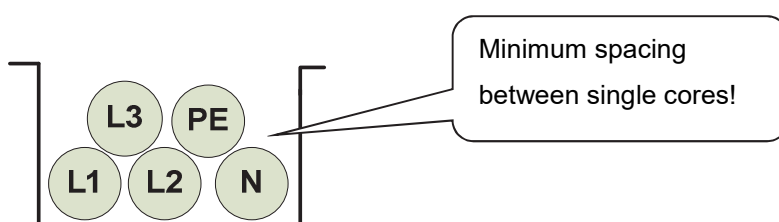

**Note:**



To avoid unnecessary loss of energy yield, the sum total of the resistive and inductive voltage drop on the power supply line at nominal load should not exceed 1 % of the line voltage.

### 4.13 DC connection PV generator

**⚠ DANGER**



**Danger to life due to high voltages from active PV strings**

Before connecting the PV strings, connect the inverter to the power supply network and to the ground bolt to ensure that the device is **safely connected to the protective conductor.**

The connection of the PV strings to the inverter or the CombinerBox can only take place **without voltage**

Live PV strings can be under lethal voltages.

The maximum allowable voltage of 25 A per DC block must be upheld. The maximum DC voltage via all inputs must under no circumstances be exceeded.

- The DC connection is effected with Sunclix-plugs and sockets. More information see see “DC-Connection”, p. 27.
- Before connecting the PV strings an isolation measurement must be taken. Whenever it is switched on, the inverter automatically checks the insulation of the PV generator. If the isolation is defective, the inverter switches off automatically. The inverter can only be started once the PV generator isolation error has been removed.
- Be absolutely sure to verify proper polarity when connecting the PV strings. Any inappropriate connection of individual strings may damage the PV generator.

Protect the connectors such that they cannot be pulled off inadvertently.

The PV generator may not exceed the following operational characteristics under any circumstances!

Device type	SelectSun 20K
Max. DC voltage at each input (USC)	1000 V
Max. voltage per DC block (DC1/DC2)	25 A
Max. DC current via all DC inputs	see “Technical data”, p. 62

**Note:**



Do not ground the positive or negative pole of the PV generator. Otherwise, the modules may experience a loss of power

## NOTICE

Reverse currents are fault currents that occur in PV systems comprising parallel strings. Given short circuits of individual modules or cells in a module, the open circuit voltage of the string in question can drop so far that the intact parallel strings will drive a reverse current through the defective string. This may result in significant heating and therefore to destruction of the string.

What is more, the reverse current may cause secondary damage.

As no separation of the strings takes place within the inverter, each string must be separately protected by a string fuse connected in series with the other string fuses. In the event of a failure, this isolates the string from the intact strings so that destruction is prevented.

### 4.13.1 DC-Connection

Please note the following information (plug type, cross section) regarding the DC power cable:

Designation	Type	Art. No. PHOENIX CONTACT	Outer Diameter	Cable Cross Section
Connectors +	PV-CM-S 2.5-6 (-)	1774687	5 – 8 mm	4 – 6 mm <sup>2</sup>
Connectors -	PV-CF-S 2.5-6 (+)	1774674	5 – 8 mm	4 – 6 mm <sup>2</sup>
PV-C PROTECTION CAP		1785430		

If necessary, the following photovoltaic Y distributors may be used:

Type	Art. No. PHOENIX CONTACT
PV-YC 6/ 1-0,12-SO3 (-/++)	1787726
PV-YC 6/ 1-0,12-SO3 (+/--)	1787739

For the adjustment of MC4 to Sunclix use the following adapter cable:

Type	Art. No. PHOENIX CONTACT
PV-AS-MC4/6-150-MN-SET	1704982

## NOTICE

In order to ensure IP65 protection, plug connectors and power supply connection cables must be matched to each other and all unused connectors shall be fitted with blanking plugs.

Only the original components by PHOENIX CONTACT can be used!  
Failure to do so could void your warranty!

## 4.13.2 Connect PHOENIX CONTACT connector (SUNCLIX)



### **⚠ DANGER**

#### **Danger to life due to high voltages from active PV strings**

- ⇒ The SUNCLIX connectors are only to be connected by electrotechnically trained personnel.
- ⇒ Never connect or disconnect SUNCLIX connectors when under load.



### **⚠ CAUTION**

#### **Danger of injury or damage to property**

- ⇒ Only use the SUNCLIX connectors together with a PV1-F type 2.5-6 mm<sup>2</sup> solar cable or UL-certified solar cable (ZKLA stranded copper wire, AWG 10-14). A safe electrical connection is only guaranteed with this cable. Further cable types can be requested from PHOENIX CONTACT.
- ⇒ When laying the solar cable, observe the bend radii specified by the manufacturer.
- ⇒ Only connect the connectors to other SUNCLIX connectors.
- ⇒ When connecting, always observe the specifications for rated voltage and rated current. The smallest mutual value is valid.
- ⇒ Protect the connector against moisture and dirt.
- ⇒ Do not submerge the connectors under water.
- ⇒ Do not lay the plug directly on the roofing.
- ⇒ Protect unplugged connectors with a protective cap (e.g. PV-C PROTECTION CAP, 1785430).

### 4.13.2.1 Connect cable

1. Strip the cable by 15 mm with a suitable tool. Ensure no individual strands are cut off.
2. Carefully add stripped conductors with drilled bunched conductors until impact. The bunched conductor ends must be visible in the spring.
3. Close spring. Ensure that the spring is locked in place.
4. Push insert into the barrel.
5. Tighten the cable screws with 2 Nm.
6. Bring together plug and bush. The connection latches.
7. By pulling the coupler, check the correct connection.

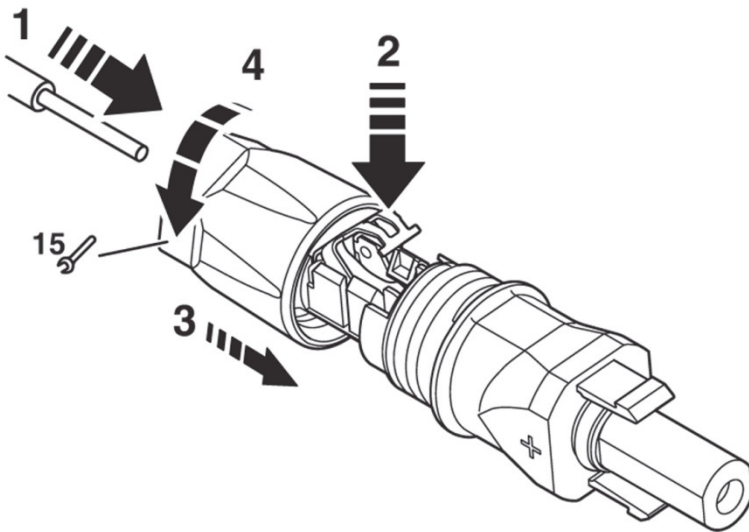

Fig. 12: Connect cable

#### 4.13.2.2 Disconnect connector

A slit screwdriver is required with 3 mm wide blade (e.g. SZF 1-0,6X3,5, 1204517).

1. Enter screwdriver as demonstrated in picture below.
2. Leave screwdriver attached and separate bush and plug from one another.

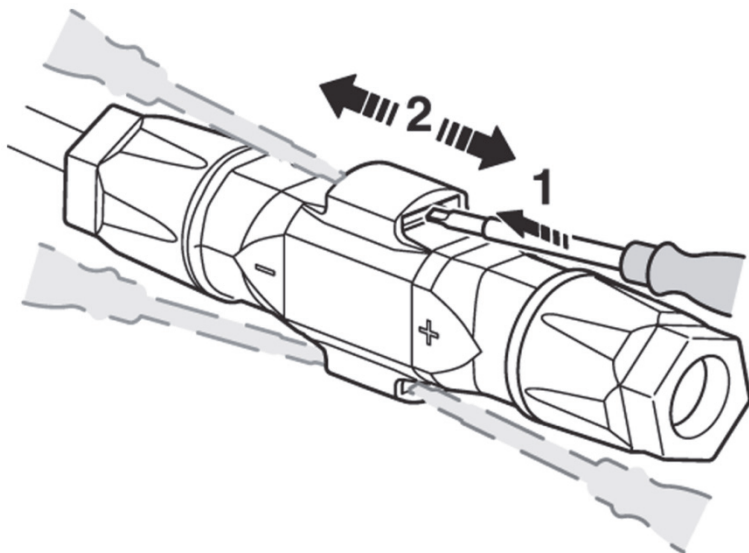

Fig. 13: Disconnect connector

#### 4.13.2.3 Remove cable

1. Unscrew cable screwing.
2. Enter screwdriver as demonstrated in picture below.
3. Pry open connection and separate barrel and insert from one another.
4. Open spring with screwdriver. Remove cable.

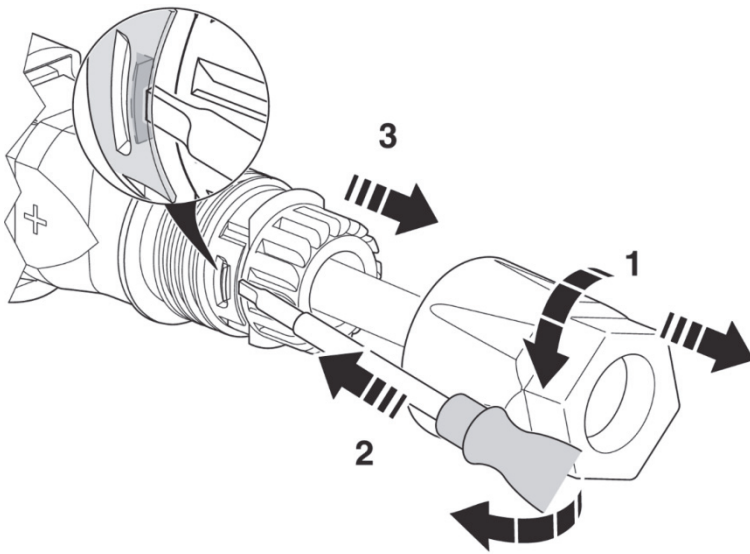

Fig. 14: Remove cable

### 4.14 Interface Port RS485

The RS485 interface supports the USS (Universal Serial Interface Protocol) and Modbus/Sunspec protocols, which can be used for transmission of data, for example, to a data logger of a remote monitoring system.

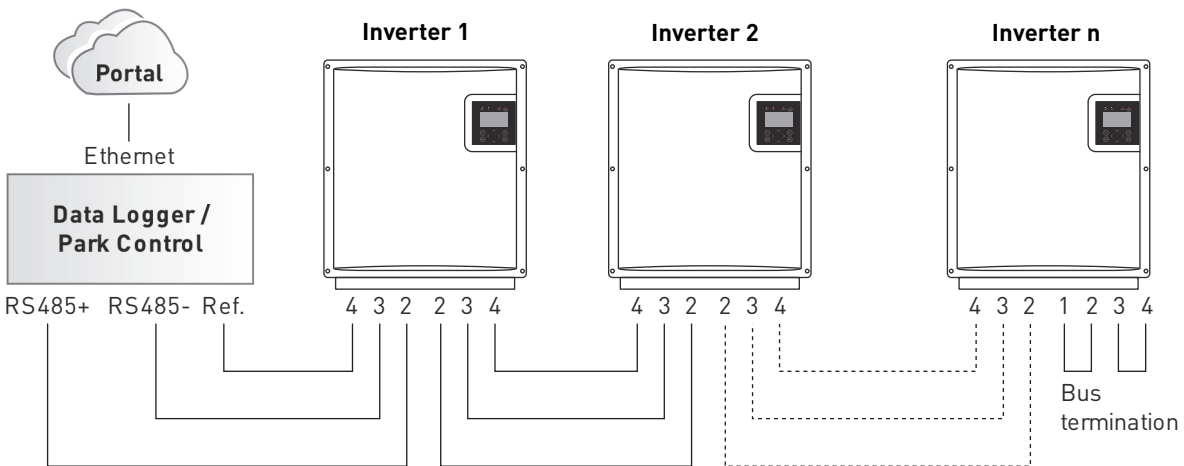

Fig. 15: Standard interface

When using this interface, please note that each device using the bus requires a unique address.

The bus termination is made by means of wire jumpers on RS485 OUT to the last bus user (inverter “n”).

Pin	Signal
Pin 1	(only used for termination)
Pin 2	RS485 +
Pin 3	RS485 -
Pin 4	Reference

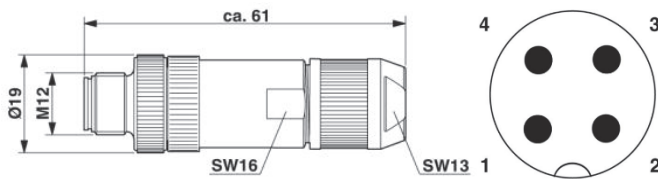

Fig. 16: Connector M12 x 1 straight, shielded; pole arrangement: male M12, 4 pins, A-coded, view of male connector side

## NOTICE

In order to ensure IP 65 protection and the required and declared conformity with the domestic EMC standard a PHOENIX CONTACT type M12MS SACC-4SC SH plug and a shielded cable must be used. The outer diameter of the connecting cable can be max. 8 mm.

Failure to observe this can lead to damage to the inverter and therefore void the warranty.

## NOTICE

### Component damage and communication malfunctions

Reversing the RS485 connecting cables and sensor cables results in defects and malfunctions. If inverters are connected in series, a reversed RS485 can damage further connected inverters.

- ⇒ Make sure that each of the RS485 connection plugs is connected with the RS485 receptacle intended for it.
- ⇒ If the connectors are reversed, correctly plug the RS485 connecting cables immediately.

## 4.15 Ethernet Interface Connection

The Ethernet interface supports Modbus TCP/IP protocol, and is Sunspec compliant, which can be used for transmission of data, for example, to a data logger of a remote monitoring system. Daisy-chaining of devices is not supported. Each inverter must be connected to an ethernet switch, in parallel.

Please use an Ethernet cable with S/FTP design (shielded foiled twisted pair) and Phoenix Contact plug type Quickon VS-08-RJ45-5-Q/IP67.

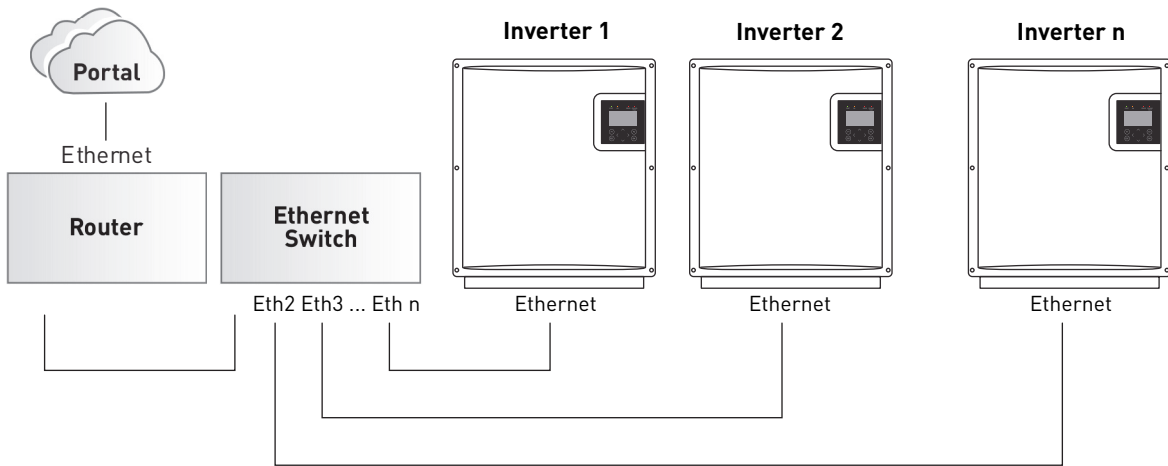

Fig. 17: Ethernet interface

## NOTICE

In order to ensure IP 65 protection, the plug type mentioned above must be used. Failure to observe this can lead to damage to the inverter and therefore void the warranty.



# 5 Commissioning

Before commissioning the inverter, be sure the following steps have been completed:

- ☑ Confirm the correct power supply connection
- ☑ Confirm the correct connection of PV strings
- ☑ Confirm that connectors are protected such that they cannot be pulled off inadvertently



**⚠ DANGER**

**Danger to life from electric shock**

- ⇒ Before switching on the device, check whether the plugs are securely fitted (locked).
- Do not pull off the connectors of the PV generator before you have met the following requirements:
- ⇒ Make the power supply line absent of voltage.
  - ⇒ Make the device absent of voltage using DC circuit breaker.
  - ⇒ Check that the DC cables of the PV generator are de-energized.
  - ⇒ Protect the voltage supply from being reactivated



**⚠ DANGER**

**Risk of electric shock and fire caused by high discharge current.**

- ⇒ Before connecting the device to the supply circuit, establish a ground connection.

## 5.1 Turning on the Device

1. Verify that the device is connected to line voltage. If not, insert the external power fuse or turn on the circuit breaker.
2. Apply voltage by turning on the DC switch. The inverter only starts if there is sufficient voltage available from the PV panels.



**Note:**

The control panel, including its status indicators, display, and operator keys, is only active when the PV generator is supplying sufficiently high voltage.

## 5.2 Setting the Country Code and the Menu Language

When switching on for the first time an initial configuration is necessary.

The country code defines the country-specific grid monitoring parameters. The menu language is automatically set when the country code is selected. The menu language can subsequently be selected as desired at any time, independent of the country abbreviation set in the menu. The country code is not set on delivery.

### NOTICE

**The selected country code can only be changed by service personnel.**

After the initial setting and confirmation of the country code the country code can only be altered within 40 hours. This is also valid for replacement devices. The country code can then only be changed by authorized service personnel.

### NOTICE

**Cancellation of the operating license!**

Operating the inverter with the wrong country code can lead to the withdrawal of the interconnection agreement from the energy supplier.  
We assume no liability for the consequences of an incorrectly set country code!

### 5.2.1 Set Country Code/Grid Guideline

The following window appears on the display after initial switch on of the DC voltage and prompts you to set the country code. You can choose from among the offered countries.

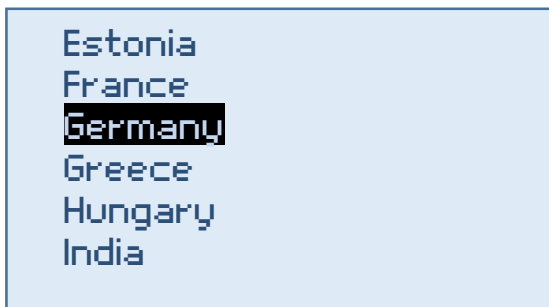

1. Use the **^** and **v** keys to select the country code which is specific for your country and your location. The menu language is selected simultaneously with the country code. However, the menu language can later be changed independently of the country code.
2. Press **OK** to confirm. Then the grid feed guideline given by the energy supplier must be selected.

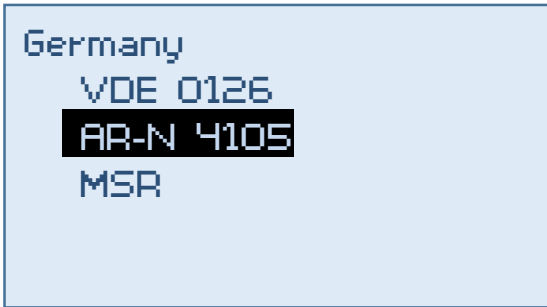

3. Select valid grid feed guideline with **^** and **v** buttons.

4. Press **OK** to confirm.

## 5.2.2 Accepting the Country Code

To be certain, you will be asked whether you wish to accept the country code. After accepting the country code it can only be changed within 40 hours.



Only confirm the country code if you are absolutely sure it is correct.

If you are not sure, press **ESC** to cancel your selection and correct the selection.

If the country code is to be accepted, then confirm with **OK**.

A restart then takes place:

⇒ "ERROR" and "GROUND FAULT" status LEDs flash red alternately.

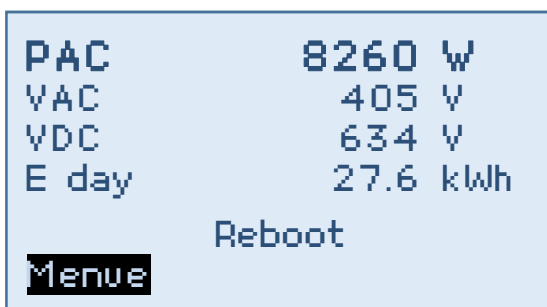

## 5.3 Device Start

- Solar modules are irradiated with sufficient sunlight.
- Country code is set.
- Time and date is set.

The following procedure follows:

- Self-test      All status LEDs are lit for approx. 6 seconds
- Check          “START” status LED lights orange.
- Activation      “START” status LED lights orange/LED “ON” flashes green.
- Feed in        “ON” status LED lights green/normally all other status LEDs are off.

## 5.4 Control Panel

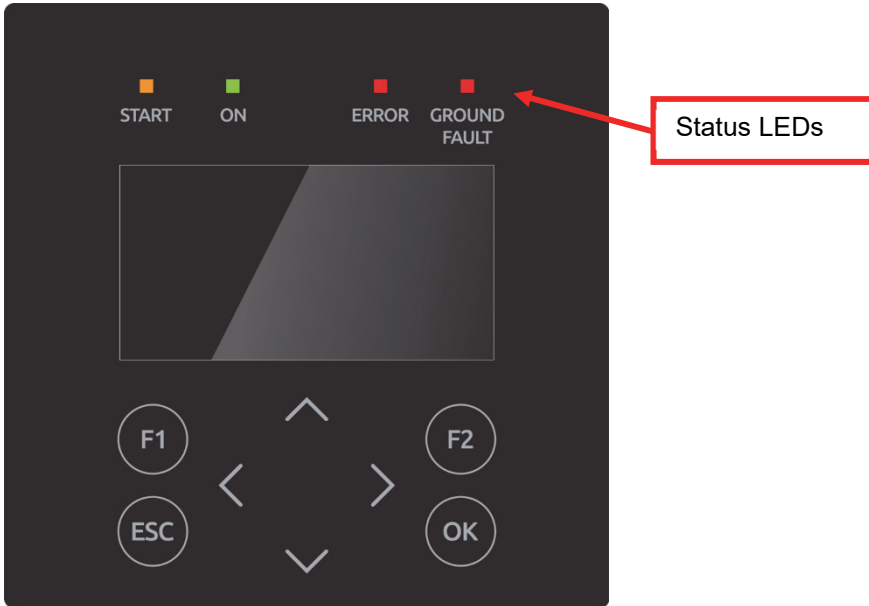

Fig. 18: Control panel with status LEDs, display and keys

<b>F1</b>	Displays the Menu
<b>F2</b>	In basic display: Reboot of display “Energy / x kWp” display: Input of standardized (normalized) data
<b>◀▶</b>	Function in the menu: Navigation within the menu level (previous menu, next menu). Function while parameters are edited: digit to the left, digit to the right (decade jump)
<b>^v</b>	Selection within the menu.
<b>ESC</b>	Acknowledge failures and exit from menu level, exit from input menu without entering data
<b>OK</b>	Confirm the selected menu (next menu level) and entered data.

## 5.5 Basic Screen

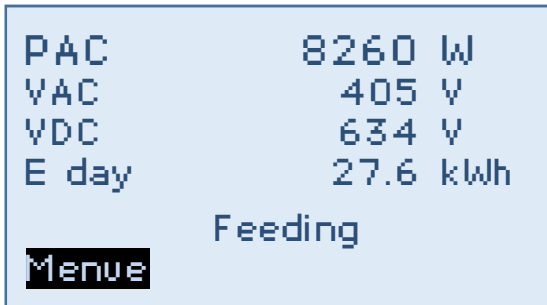

Fig. 19: Operating mode display

PAC = Current feed power in Watts (W)

VAC = Line voltage in Volts (V)

VDC = Solar cell voltage in Volts (V)

E day = Energy yield of the day in kWh

## 5.6 Graphical Display

Press the **←** arrow key once to display the development of the day's feed power.

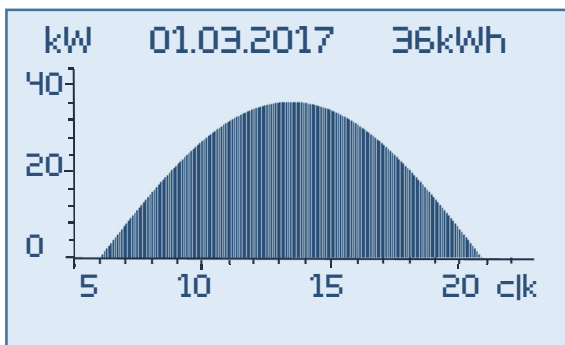

Fig. 20: "Today's" feed power display

Press the **▼** arrow key to display the development of the previous days.

Press the **ESC** key to return to the basic screen display.

## 5.7 Energy Yield Data Display

Press the **➤** arrow key to display the current yield data and the operating hours having currently elapsed.

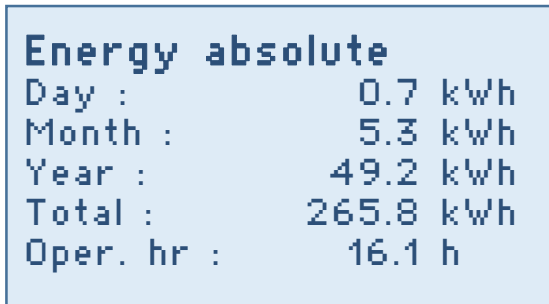

Fig. 21: Energy yield absolute display

## 5.8 Standardized Energy Yield Data Display

Press the **➤** arrow key, then the **▼** arrow key to display the development of standardized energy yield data.

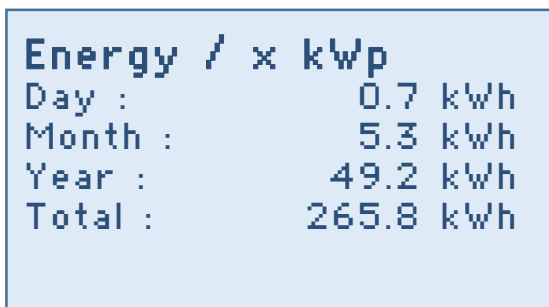

Fig. 22: Energy yield normalized on the display

Press the **ESC** key to return to the basic screen display.

## 5.9 Input of Standardized Data

To change the normalization, press the **F2** key and enter the currently connected PV generator power as follows:

- ◀▶** keys:            Press the **◀** key to select the digits before the point.  
                         Press the **▶** key to select the digits after the point.
- ^** key:                Press the **^** key to increment the selected digit by 1.
- ▼** key:                Press the **▼** key to decrement the selected digit by 1.

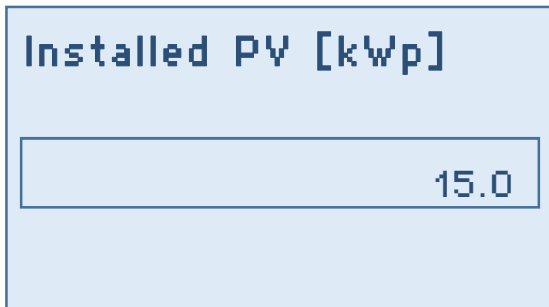

The image shows a digital display interface for entering standardized data. At the top, the text "Installed PV [kWp]" is displayed in a blue, monospaced font. Below this text is a rectangular input field with a thin blue border, containing the numerical value "15.0". The entire display area has a light blue background.

Fig. 23: Standardized data input display

Press the **OK** key to apply the set value.

Press the **ESC** key to discard the value and display the previous "normalized yield" level.

Press the **F1** key to display the menu.

## 5.10 Menu Structure

The menu structure serves as a support to change to the individual information displays and setting displays.

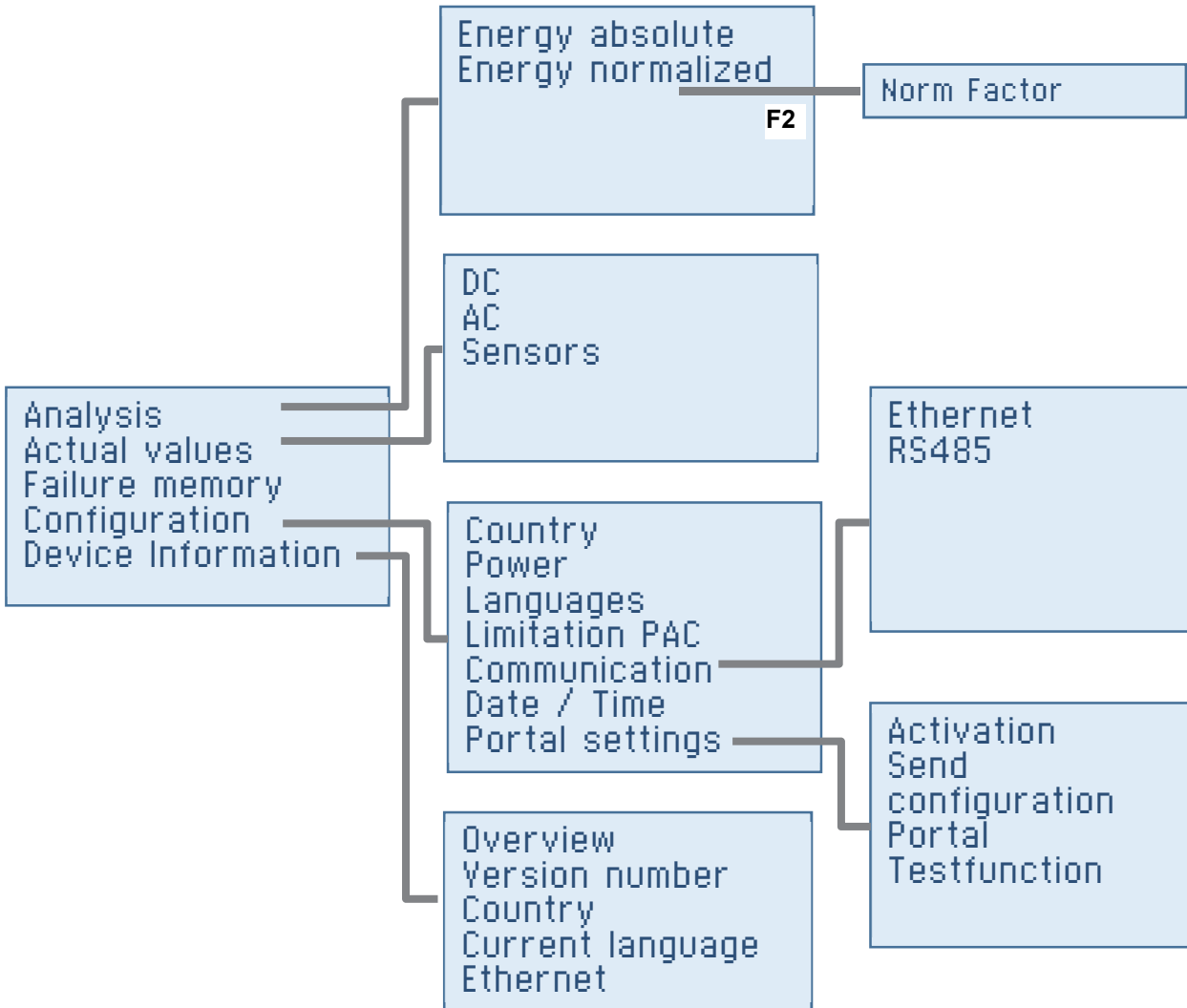



## 6 Configuration

### 6.1 Changing the Menu Language

The language selection has no effect on the country code. Proceed as follows to change the menu language:

1. Press **F1** to open the menu.
2. Use the **▼** and **▲** keys to select the fourth menu item “Configuration”.

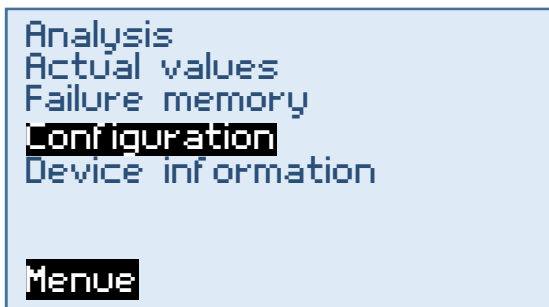

3. Press **OK** to confirm.
4. Use the **▼** and **▲** keys to select the first menu item “Languages”.

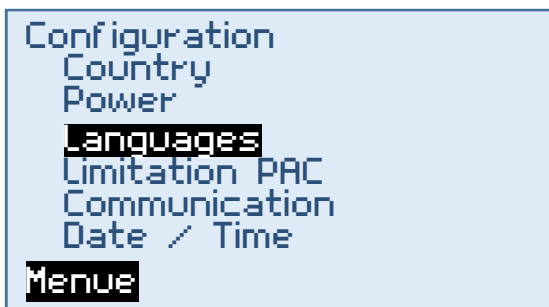

5. Press **OK** to confirm.
6. Use the **▼** and **▲** keys to select the desired menu language.
7. Press **OK** to confirm.
  - ⇒ The menu switches to the selected language. The display is initially empty.
8. Press **ESC** to return to the menu.

### 6.2 Limitation of the Power Output

Proceed as follows in order to limit the power output of the inverter:

1. Using the **F1** key, select the menu item “Configuration” and confirm with the **OK** key.
2. Select the sub-menu “PAC Limit” and confirm with the **OK** key.
3. Enter the invert power output as percentage of the nominal power and confirm with the **OK** key.

⇒ The power limit is immediately applied.

## 6.3 Monitoring Portal

The SelectSun 20K inverter can be connected to a monitoring portal using direct Ethernet connection to the internet, or via RS485 and a control device.

Once an internet connection is established, the inverter will automatically start to send data every 5 minutes. The sending interval can be changed with the configuration tool.

You can use the activation code provided on the type label of the inverter to assign one or more inverter to a PV system.

## 6.4 PC Configuration Tool

You can upgrade the firmware of the inverters and change country-specific parameters of the inverter with the PC Configuration Tool. You can connect the PC with the inverters via Ethernet or USB using a RS485-USB converter.

For extended settings, you will receive a personal password on request from the Selectronic Australia Pty Ltd Service.

### Functions

- Firmware update
- Export of inverter data
- Feed-in conditions voltage and frequency
- Ramp starting time in the event of a grid error
- Average voltage monitoring
- Phase conductor voltage monitoring
- Frequency-dependent power reduction
- Actual voltage monitoring (rapid disconnection)
- Actual frequency monitoring
- Reactive power ( $\cos \varphi$ )
- Power-up time
- K factor (fault ride through)

## 6.5 Communication via Ethernet

The settings for the Ethernet communication can take place either manually or automatically (via DHCP). Manually is the default setting.

### 6.5.1 Automatic Setting via DHCP

1. Navigate to Menu **Configuration > Communication > Ethernet > DHCP**.
2. Enter "1" in DHCP input field.
3. Press **OK** to confirm.
4. Restart inverter by opening and re-closing the DC switch.

⇒ The settings for IP address, subnet mask, standard gateway and DNS are automatically taken from the DHCP server, e.g. the router.

### 6.5.2 Manual Setting

In order to ensure a trouble-free operation, all values must be given by the responsible network administrator and individually set in each inverter.

1. Navigate to **Configuration > Communication > Ethernet > IP address**.
2. Enter IPv4 address. The IPv4 address is arbitrary, but must be consistent throughout the subnet.  
Default value: **192.168.130.30**
3. Press **OK** to confirm.
4. Navigate to **Configuration > Communication > Ethernet > Subnet mask**.
5. Enter IPv4 mask. The IPv4 mask is arbitrary, but must be consistent throughout the subnet  
Default value: **255.255.0.0**
6. Press **OK** to confirm.
7. Navigate to **Configuration > Communication > Ethernet > Standard gateway**.
8. Enter the address of the router that allows connection to the internet  
Default value: **192.168.1.1**
9. Press **OK** to confirm.
10. Navigate to **Configuration > Communication > Ethernet > DNS**.
11. Enter arbitrary IPv4 address of the superior DNS server  
Default value: **0.0.0.0**
12. Press **OK** to confirm.
13. Restart inverter.

## 6.6 Communication via RS485

For monitoring via RS485, you need to use a control device to forward data to the monitoring portal.

You need to assign a unique USS address to each connected inverter.

Addresses: 1 to 31

This address is required for communicating with the inverter via RS485.

⇒ After entering the address, restart the inverter to activate the new address.

Protocol type: 1: USS protocol (preset)

2: (not used)

3: Meteocontrol USS

4: Modbus RTU Sunspec

(address 0 cannot be used – address 0 is automatically set to address 1!)

5: Multimode USS / Modbus RTU Sunspec

(in Multimode, you cannot use USS address 0 and 2!)

Baud rate: 57600 (preset and recommended)

115200 (for short RS485 networks)

Parity: even

Handshake: no

Data bits: 8

Stop bits: 1

Protocol: USS protocol

## 6.7 Portal Monitoring

To ensure the inverter sends data via Ethernet to the monitoring portal, the portal monitoring must be active.

Open Menu Configuration > Portal Monitoring and enter the following value:

0 = Portal monitoring via Ethernet not active

1 = Portal monitoring via Ethernet active



### Notice

If the inverter is connected with RS485 to the control device, the setting 0 (Portal Monitoring via Ethernet not active) must be used!

## 6.8 Sending Config

### **Menu Configuration > Portal monitoring > Config sending**

The configuration data is required by the monitoring portal in order to recognise the inverter. If you want to send it manually, select the menu and set the parameter to 1. If the sending was successful, the parameter will be set back to 0 automatically.

## 6.9 Portal Test Function

### **Menu Configuration > Portal monitoring > Portal Test**

On request of our service, you can send a test data package to the portal. Open the menu and select „yes“.

# 7 Troubleshooting

## 7.1 Self-Test – Error Message

After the initialization routine, the system runs through a self-test. The individual parts of the system, such as firmware and dataset, are checked and data is read in from the power control board. If an error continues to be detected, possible remedial measures must be taken according to the type of error.

## 7.2 Transient Failure

In certain operating states the inverter goes temporarily offline.

Unlike malfunctions, “transient failures” are automatically acknowledged by the inverter which attempts to restart once the error no longer exists.

A transient failure is indicated by the red LED "ERROR" on the control panel flashing and remains stored in the fault memory even in the event of a power failure.

## 7.3 Faults

Pre-configured and customizable limit values are continuously monitored during ongoing operation. In order to be protected, the inverter power section is isolated from voltage supply if a limit value is exceeded or if a failure occurs. However, the DC and AC voltages may still be available. The corresponding fault message appears in the display.

The fault is indicated on the control panel by the red "ERROR" LED emitting steady light.

Fault messages are stored in the fault memory, where they will remain even in the event of a power failure. The fault memory can be called up via the display. The last 100 faults are recorded in the fault memory. The latest fault is kept at memory location S0, the oldest at S100. A new fault is always stored to memory location S0. When this happens, any fault already at memory location S100 will be lost.

## 7.4 Fault Acknowledgement

After shutdown due to a fault, the device remains locked against reactivation until the fault is acknowledged. It is not possible to acknowledge the fault while the cause of the fault still exists. The fault can only be acknowledged after the cause of the fault has been eliminated.

- ⇒ To acknowledge the fault message, press the ESC key or turn the inverter off with the DC switch and wait min. 30 seconds to turn the inverter ON again.

## 7.5 List of Error Messages



### Note

Under certain weather conditions, condensation may form in the display. This is normal and causes no malfunction of the inverter.

Error Code	Text	Description	Action
90006	Grid overvoltage	Phase overvoltage (AC) has been detected.	Check the phase voltages (with a true RMS measurement device). If you consider the phase voltages to be in order, contact Service.
90007	Grid undervoltage	Phase undervoltage (AC) has been detected.	
90008	Overfrequency	The grid frequency has exceeded the limit value.	As long as the inverter is detecting an over or under-frequency: check the frequency of the phases. If you consider the frequencies to be in order, contact Service
90009	Underfrequency	The grid frequency has dropped below the limit value.	
9000A	DC link 3	DC-voltage measurement error.	Wait for the measurements to become stable again. If this takes more than 2-3h, please contact Service.
9000B	DC link 1	Imbalance low: Difference between the DC link voltages is too high.	
9000C	DC link 2	Imbalance high: Difference between the two boosted DC link voltages is too high	
9000D	DC link 4	The boosted DC-voltage has dropped below the mains peak value	
90010	DC link 5	The boosted DC link voltage is too high.	
90011	DC link 6	The DC link voltage is too high.	
90017	Communication LT	Communication malfunction between power section and control and regulation unit	The inverter will acknowledge the error automatically. If problem occurs repeatedly, contact Service
90018	Grid frequency LT	Power section has detected under/overfrequency	As long as the inverter is detecting a power section grid frequency: check the frequency of the phases. If you consider the frequencies to be in order, contact the Service

Error Code	Text	Description	Action
90019	Grid overvoltage LT	The power section has detected a phase overvoltage.	As long as the inverter is detecting a grid overvoltage or under voltage: check line voltages (with a true RMS measurement device). If you consider the line voltages to be in order, contact the Service.
9001A	Grid undervoltage LT	The power section has detected a phase undervoltage.	
9001B	RCD fault	The AFI-Board unit has detected a residual current.	Check system isolation. As long as you consider the isolation impedance to be in order, contact Service.
9001D	RCD warning	Leads to an immediately shutdown	
90020	Initialisation C1	Initialisation has failed.	Restart inverter. If this does not rectify the error, contact Service.
90021	Initialisation C0		
90024	SR parameter error	Error in parameter initialisation. The device has been permanently shut down.	Please contact Service.
90029	Update fault	Update failed	The update has failed. Contact Service.
9002A	Keep Alive	Internal communication monitoring has determined a fault.	Please contact Service.
9002B	Update End	Update successful notification.	An update was successfully completed. The device will resume normal operation.
9002C	AntilandPhase Shift	Islanding of the connected grid section has been detected	Wait for the grid to become stable again
9002D	AntilandRocof		
9002F	FFS is read-only	Internal data can't be written anymore.	Please contact Service.
90030	DC share too high	The measured DC-Part in AC current exceed the defined limit.	
90031	ETH link lost	The Ethernet cable has been removed	Check the Ethernet cable on the device and the receiver (router, switch) for a correct fit. If the cables are correctly connected and should



Error Code	Text	Description	Action
			the notification still be there, please contact Service.
90032	Restart	The system has been rebooted.	Should these notifications occur repeatedly during daily operation, please contact Service.
90050	AC condition	AC switch on condition not fulfilled	Wait until the network is stable
90051	DC condition	DC switch on condition not fulfilled	Wait until the solar voltage is high enough
90052	User lock active	The inverter can't connect to the grid, as the User-lock has been set.	Deactivate user lock
90053	Communication SR	Internal communication problems	Fault is independently resolved after a few minutes. If not, switch device off and on again. If this does not resolve the problem, contact Service.
90054	Overvoltage 2	The phase voltage has exceeded the limit value of the voltage average monitor for too long.	As long as the inverter is detecting the voltage error: monitor line voltages (analyse grid). If you consider the line voltages to be in order, contact Service.
90055	Grid overvoltage	Line-to-line overvoltage (AC) detected	
90056	Grid undervoltage	Line-to-line undervoltage (AC) detected	
90057	Watchdog C0	Internal protection function is triggered.	Contact Service.
90058	Watchdog C1		
90059	LT Firmware	The software of the power section is defective.	
90060	FRT stability	Stability issue with the DC link detected.	Please contact the service if it happens repeatedly
90061	Update fault	This notification can be ignored.	No measures necessary.
90062	Fault ride through	Grid-instability which is handled with respect to the grid code standards.	

Error Code	Text	Description	Action
A0013	PM isolation RCD SR	The measured value of the residual currents are over the limits: Measured value >150 mA -> Trip within 20 ms Measured value >60 mA -> Trip within 130 ms Measured value >30 mA -> Trip within 280 ms	Check system isolation. If you consider the system isolation to be in order, contact Service.
A0020	External cut-off	External monitoring has triggered a disconnection.	During the inverter detects an external cut-off: Verify external cut-off signal . Possible causes: wire breakage or wrong sensor selected. Refer to the manual for the right settings.
A0021	ARC fault detected	Arc fault detection has triggered a disconnection	Reset the arc fault detector. Press ESC on the Display.
A0022	Ext. OVGR Signal	External stop signal OVGR is detected.	During the inverter detects OVGR: Verify External stop signal OVGR. Possible causes wire breakage.
A0102	Overtemperature LT 1	Cooler overtemperature (right)	Check temperature of direct surroundings and reduce this as required.
A0103	Overtemperature LT 2	Interior overtemperature (left)	
A0104	Overtemperature LT 3	Interior overtemperature (right)	
A0105	Overtemperature LT 4	Cooler overtemperature (left)	
A0106	Supply voltage LT	Supply voltage at the power section is too low.	Please contact Service
A010C	PM isolation LT	Power section detects an isolation error on activation.	Check system isolation. If you consider the isolation resistance to be in order, contact Service.

Error Code	Text	Description	Action
A010E	Device fault LT	Power section hardware shutdown	Note: When did the error occur (precisely: day, kW output, time).
A0114	PM isolation RCD LT	Residual current measured from the power section exceeded the limits. residual current > Limit values of 20 mA, 130 mA, 280 mA respectively	Please contact Service
A0116	R-detect	0	Do nothing. The inverter will acknowledge the error automatically. If problem occurs repeatedly, contact Service.
A0117	Isolation test unit	Test isolation test is taking too long.	Please contact Service
A0118	Voltage offset LT	Offset adjustment values between power section and control and regulation unit divergent	
A011A	Activation LT 1	Voltage booster self-test failed.	Do nothing. The inverter will acknowledge the error automatically. If problem occurs repeatedly, contact Service.
A011B	Activation LT 2	DC link voltage drop during activation	
A011C	Activation LT 3	Target value for balancing is invalid.	
A011D	Activation LT 4	Balancing has failed.	Please contact Service
A011E	Activation LT 5	Voltage booster malfunction	
A011F	Parameter error LT 5	Faulty reading or writing process in power section memory	1.) Switch off device with DC disconnecter. 2.) Wait until the display has turned off completely. 3.) Switch on device with DC disconnecter. If this does not rectify the error, contact Service.
A0172	P24V LT aux. supply	P24V supply voltage at the power stack is too low.	Please contact Service
A0173	P5V LT aux. supply	P5V supply voltage at the power stack is too low.	

Error Code	Text	Description	Action
A0174	P15V LT aux. supply	P15V supply voltage at the power stack is too low.	
A0178	Temp. Sensor KR LT	checking open loop or short loop for temperature sensor cooler right	
A0179	Temp. Sensor IL LT	checking open loop or short loop for temperature sensor cooling interior left	
A017A	Temp. Sensor IR LT	checking open loop or short loop for temperature sensor cooling interior right	
A017B	Temp. Sensor KL LT	checking open loop or short loop for temperature sensor cooler left	
A017C	N15V LT aux. Supply	N15V supply voltage at the power stack is too low.	
A017D	Phase defect	an error has been detected in the power modules	

# 8 Options

## 8.1 Irradiation and Temperature Sensor

For recording the irradiation and the module temperature, an irradiation and temperature sensor can be connected to the sensor interface of the inverter.

The sensor comes with a 3 meter UV-resistant connecting line (5 x 0.14 mm<sup>2</sup>). The line can be extended with a 5 x AWG 23 (0.25 mm<sup>2</sup>) shielded line, max. 328 ft (100 m).

### 8.1.1 Inverter Sensor Interface

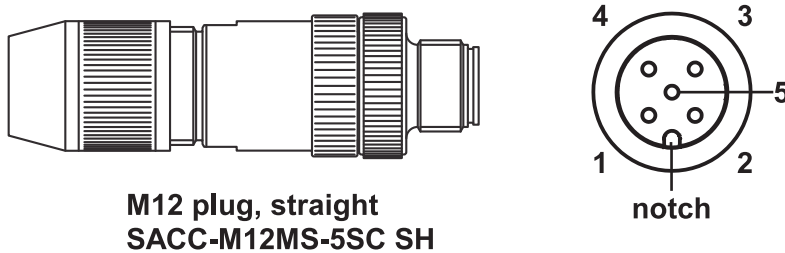

Fig. 24: Connector M12 x 1 straight, shielded; pole arrangement: male M12, 5 pins, A-coded, view of male connector side, PHOENIX CONTACT designation: SACC-M12MS-5SC SH

Inverter sensor pins	Signal
Pin 1	Supply voltage (24 VDC, max. 2 W)
Pin 2	Ground
Pin 3	Signal Input 1 (0-10 V)
Pin 4	Signal Input 2 (0-10 V)
Pin 5	Shield

### 8.1.2 Sensor Type Si-13TC-T-K Cable

Sensor cable color	Signal
Red	Supply voltage (12-28 VDC)
Black	Ground
Orange	Measurement signal irradiation (0-10 V)
Brown	Measurement signal temperature (0-10 V)
Black, thick	Shield

## 8.1.3 Assembling of the Sensor Plug

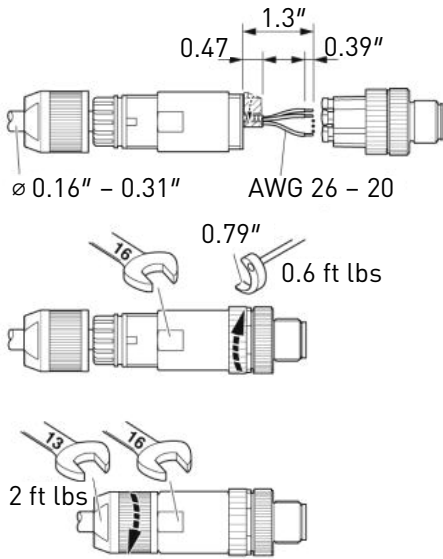

## 8.1.4 Connection of the Sensor at the Solar Inverter

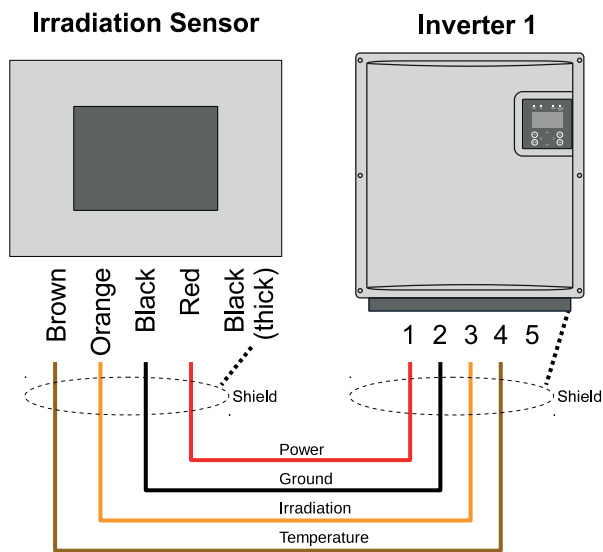

Fig. 25: Standard connection at a solar inverter (not applicable at AFCI variant)

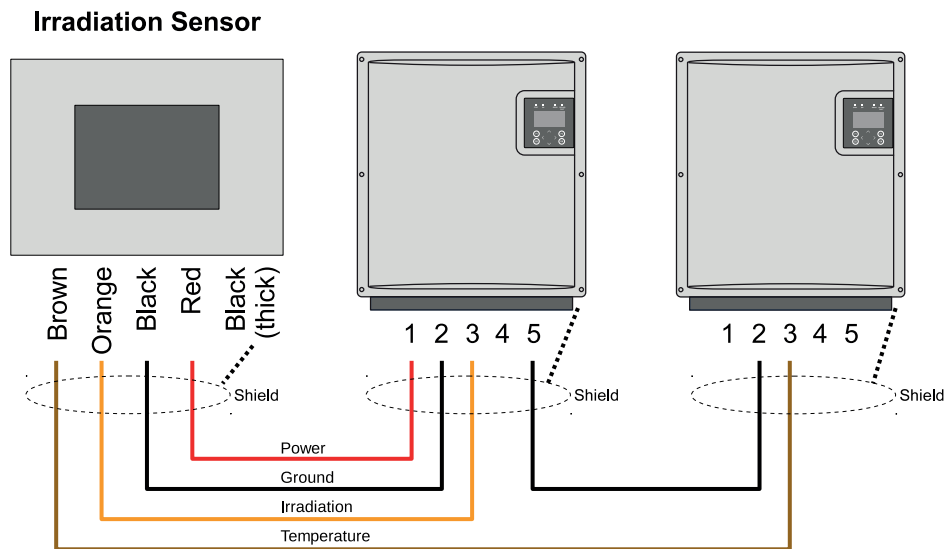

Fig. 26: Connection to two inverters (for AFCI variant)

In the AFCI variant, the irradiation and temperature sensor is connected individually to one inverter.

### 8.1.5 Configuration

The actual values of the sensor are shown on the display of the inverter at **Actual values > Sensor**.

The assignment of the sensor signals can be configured with PC configuration tool.

The data are recorded by the datalogger and are visible within the monitoring portal.



**Note:**

The shield of the sensor line (dotted line) must be applied to PIN 2 and PIN 5!  
The outer diameter of the connecting cable can be max. 8 mm.



**Note:**

If you do not use the temperature input, wire a jumper across PIN 4 and PIN 5. Alternatively, you can also wire the jumper to the intermediate terminal point (cable extension).

The actual values of the sensor can be viewed in **Actual values > Sensor**. The data continues to be recorded with the data logger and can be viewed via the monitoring portal.

## 8.2 External Turn Off Signal

### 8.2.1 Overview

The SelectSun 20K inverters have an internal grid protection relay and section switch.

Depending on local connection, installation instructions and the selected line voltage level either the internal grid protection relay can be used with section switch, or an external grid protection relay must be used with section switch also.

It is also possible to combine the internal to the external grid protection relay.

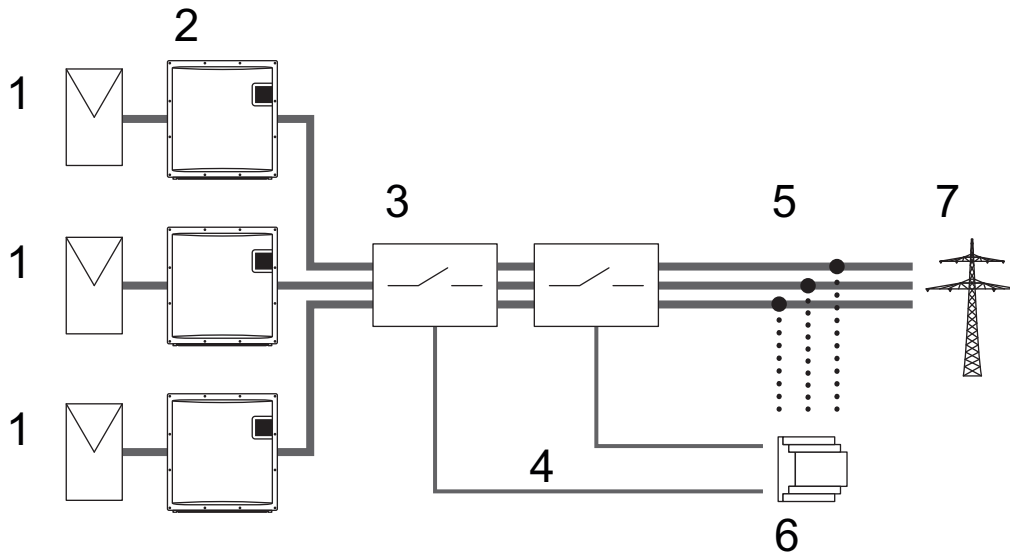

- 1 Photovoltaic modules
- 2 Solar Inverter
- 3 Three phase, redundant section switch
- 4 Control line
- 5 Grid measurement
- 6 Grid protection device
- 7 Public grid

### 8.2.2 Function

The internal section switches of the inverter can be controlled by an external signal.

At a signal voltage between 7.5 and 10 V the inverter feeds into the grid. If the signal voltage falls below 7.5 V, an error message will occur and the inverter will stop to work within the configured switch of time.

<b>Nominal voltage</b>	10 VDC
<b>Voltage (operation)</b>	7.5 ... 10 VDC
<b>Voltage (Stop)</b>	0 ... 7.5 VDC
<b>Standard switch-off time inverter</b>	50 ms
<b>Switch-off time range</b>	50 ms ... 100 ms



## 8.2.3 Connections of the External Stop Signal (DRM 0)

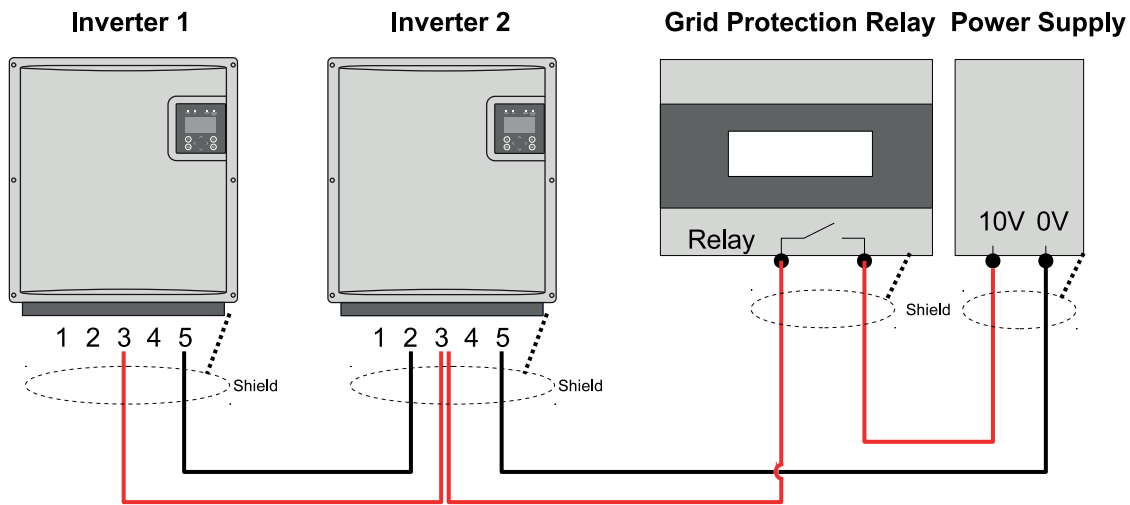

Fig. 27: Single external stop signal

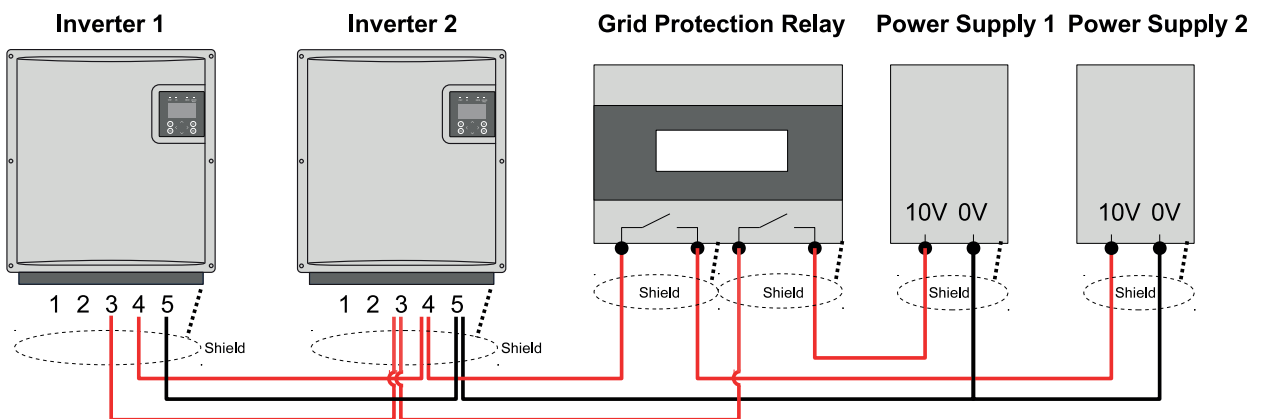

Fig. 28: Redundant external stop signal (does not apply to AFCI variant)

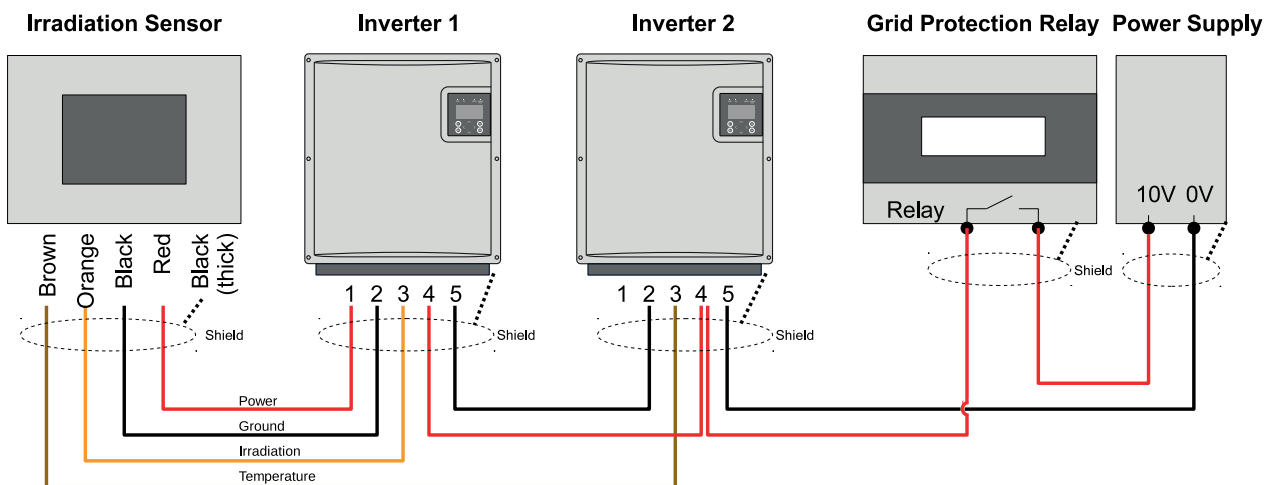

Fig. 29: Single external stop signal with sensor connected (does not apply to AFCI variant)



**Note:**

In order to ensure the function of the switch off signal, the sensor selection must be correctly set in the inverters.

The configuration of the inverter is possible with the PC configuration tool. Other switch off times required by the utility, for example, or other voltage ranges can be configured here. It is also possible to deactivate the internal grid protection relay function of the inverter if an external grid protection relay is connected to switch off the inverter and if your grid supplier allows it.

### 8.2.4 Configuration of the External Stop Signal (DRM 0)

The sensor function can be configured at the inverter display at **Configuration > External Signal**.

It is also possible to perform the configuraton with the PC configuration tool. This PC tool allows to define different voltage ranges and switch-off times. The inverter integrated grid protection can be deactivated if authorized by the grid operator.

**⚠ DANGER**



**Risk of electric shock and fire caused by high discharge current.**

⇒ Before **connecting** the device to the supply circuit, establish a ground connection.

### 8.2.5 Attach the DRM 0 Sticker

DRM0  
(Australia)

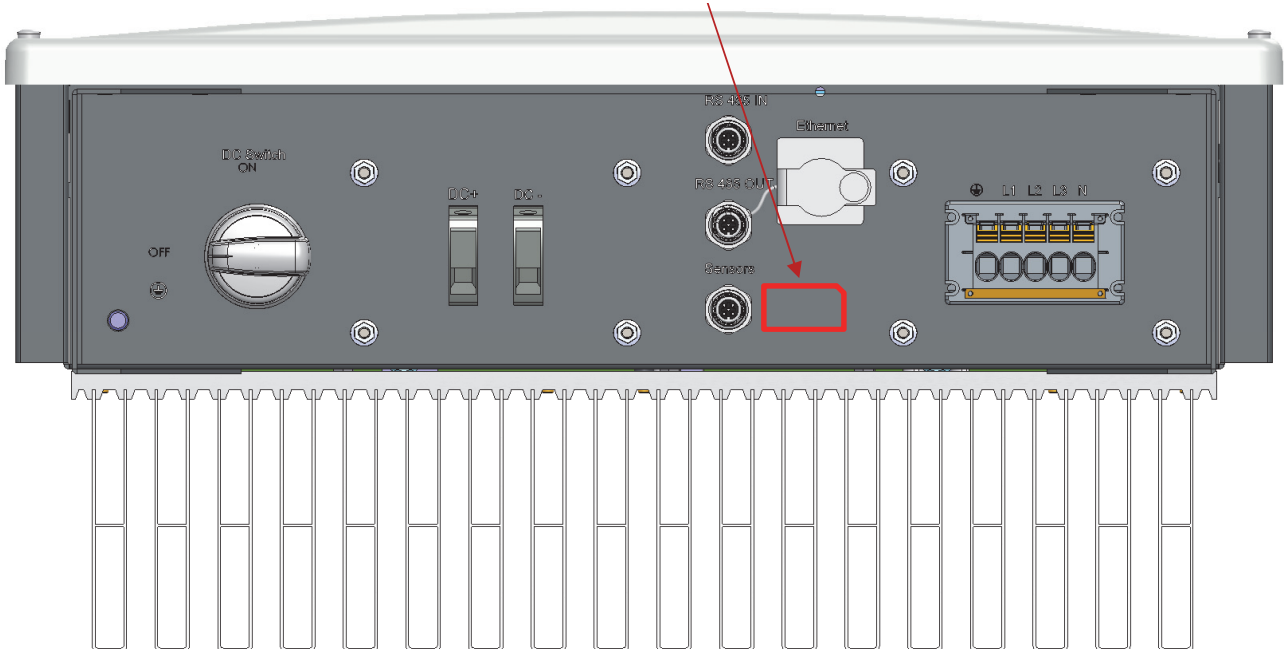

⇒ Attach the “DRM 0 (Australia)” sticker next to the **Sensor** connector. The sticker can be found enclosed to the instruction manual.

# 9 Maintenance

## 9.1 Maintain the Inverter

The cooling of the inverter is exclusively through natural convection, therefore the cooling system is maintenance free.

Periodically, based on site conditions, visual inspection of the cooling fins is recommended to identify any debris accumulation that could occur. If found, the debris must be removed to ensure that the convection cooling is not inhibited.

Cleaning with high-pressure cleaners is prohibited.

Annually, the DC switch has to be operated without electricity 5 times.

# 10 Decommissioning



## ⚠ CAUTION

### Danger of injury

- ⇒ When decommissioning the inverter, take the weight **38.4 kg** into account.
- ⇒ Do not open device. Opening the device voids the warranty.

## NOTICE

### Danger of damage to property

- ⇒ Do not use the cover to hold the device. Only use the four holding grips to move the device.

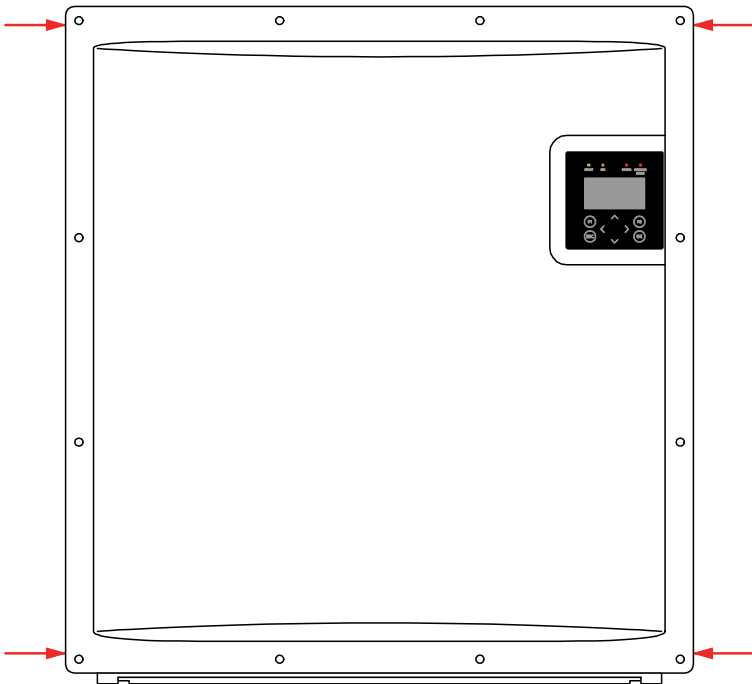
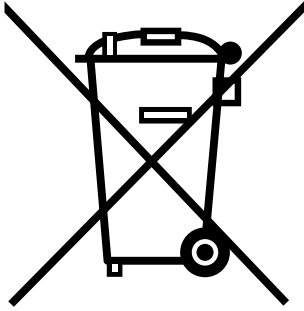

Fig. 30: Handles on the inverter

## 10.1 Remove Inverter

1. Deenergize the inverter completely.
2. Remove all cables from the inverter.
3. Loosen the screws (M5x20) securing the inverter to the wall-mounting bracket.
4. Remove the inverter from the wall-mounting bracket.

## 10.2 Disposal



Dispose of the packaging and replaced parts according to the rules applicable in the country where the inverter is installed.

Do not dispose of the inverter with normal domestic waste.

The inverter conforms to RoHS. That means that the device can be taken to municipal disposal sites for household appliances.

Selectronic Australia Pty Ltd takes the inverter back completely. Please contact the Service team.

# 11 Technical data

## 11.1 Inverter

Type	20K
Art no.	865A020.000
<b>DC data</b>	
MPPT Range at nominal power (V)	490–850
Max. voltage DC (V)	1,000
DC start voltage (V)	350
Max. operational current DC (A)	41.8
Max. short circuit current ISC of PV system (A)	50
MPP trackers	1
Number DC inputs	6 x Plus, 6 x Minus Phoenix Sunclix®
<b>AC data</b>	
AC nominal power (kW)	20
AC grid connection	L1, L2, L3, N, PE
Nominal power factor	1
Nominal power range	0.8i ... 0/8c
Nominal voltage AC (V)	400
Voltage range AC (V)	320–460
Nominal frequency (Hz)	50, 60
Frequency range (Hz)	45–65
Max. AC current (A)	30.4
Max. distortion factor THD (%)	1.8 %
Max. efficiency (%)	98.2 %
Feed-in from (W)	50
Self-consumption night (W)	< 0.5
<b>Ambient conditions</b>	
Cooling	Natural convection
Ambient temperature (°C)	-25 – +55 °C
Storage temperature (°C)	-25 – +55 °C
Transport temperature (°C)	-25 – +70 °C
Relative air humidity (%)	4 – 100

<b>Type</b>	<b>20K</b>
Art no.	865A020.000
Site altitude (m above sea level)	3,843*
Noise level (dBA)	< 45
Type of protection (IEC 60529)	IP65
<b>Safety and Protection</b>	
DC switch / Isolation monitoring	Yes / yes
Grid monitoring	Voltage, Frequency, Anti islanding, DC injection
Grid separation	Redundant grid relay according to VDE 0126-1-1
Residual Current Monitoring (RCD)	Yes
Protection class (IEC 62103)	I
Overvoltage category (EN 60664-1)	DC: II, AC: III
<b>General Data</b>	
Interfaces	Ethernet, RS485, Sensor (Temperature sensor, Irradiation sensor, Remote stop signal)
Dimensions W x H x D (mm)	535 x 601 x 277
Dimensions with packaging W x H x D (mm)	595 x 640 x 395
Device weight (kg)	38.4 kg
Weight with packaging (kg)	43.5 kg

\*\* Note derating of max. DC voltage:

Amount over NN.	Max. DC voltage
Up to 3,843 m	1,000 V
Up to 4,000 m	971 V

# 12 Certificates

**EU directives**

Directive 2014/30/EU

Directive 2014/35/EU

**Safety**

IEC 62109-1:2010 / IEC 62109-2:2011

DIN VDE V 0126-1-1:2013-08

IEC 62116:2014

IEC 61727:2004

IEC 61683:2000

IEC 60068-2-1:2007

IEC 60068-2-2:2007

IEC 60068-2-30:2005

IEC 60068-2-78:2001

EN 60529:1991 + A1:2000 + A2:2013

IEC 60364-7-712:2016

**EMC Immunity**

EN 61000-6-1:2007

EN 61000-6-2:2005

**EMC Emissions**

EN 61000-3-12:2011

EN 61000-3-11:2000

EN 61000-6-3:2011

EN 61000-6-4:2007 + A1:2011

**Grid Codes / Guidelines**

AS/NZS 4777.2:2015, AS 4777.3-2005, AS/NZS 3100:2017

VDE AR-N 4105:2011

BDEW Mittelspannungsrichtlinie (medium voltage directive) TR3 Rev 23, TR4 Rev 7, TR8 Rev 6

CEI 0-16:2012, 0-16 V1:2013, 0-16 V3:2014

CEI 0-21:2012-06, V1:2012-12, V2:2013-12, 2014-09, V1:2014-12



# 13 Contact

Please address any questions on malfunctions or technical problems to:

Service Hotline: +61 (3) 9727 6600

In Australia, Freecall 1800 006 474

## Online

Website: <http://www.selectronic.com.au/contact/>

Support Ticket: <http://www.selectronic.com.au/support/ticket.htm>

## You should have the following data at hand:

- Exact description of the error with error code
- Device type
- Serial number
- Firmware version