



myGrid Installation Notes

Introduction

myGrid kits provide an easy to install, compliant, Solar Hybrid (On-Grid) or Off-Grid battery system.

These installation notes outline all the processes required to effectively install each of the myGrid kit configurations helping the installer to gain the most benefit from using a myGrid kit.

myGrid Installation Overview

There are two major parts to each kit:-

- SP PRO or SP PRO GO Interactive Inverter Charger
- Battery Enclosure including side mounted DC switchbox



The battery enclosure is designed to sit on the floor and the SP PRO or SP PRO GO is wall mount. Connection points between these two parts have been designed to allow flexibility in positioning to suit many varied locations.

The battery enclosures in the myGrid kit are modular and each section is called a frame. Each frame can hold four myGrid batteries. The picture above is a two frame battery enclosure plus left hand mounted DC Switchbox. The DC Switchbox contains the main battery circuit breaker and the precharge/battery sense circuit breaker under a protective cover and can be mounted on either the left hand side or the right hand side of the battery enclosure.



INSTALLATION LOCATION

The myGrid kit includes short cabling for minimum losses so the SP PRO or SP PRO GO and battery enclosure need to be installed within close proximity of each other. The battery enclosure and the DC switchbox is suitable for installation outside however it is advisable that the installation is somewhat protected from the elements.

The distance to the main AC Switchboard must also be considered. AC feeds are required to go into and out of the SP PRO or SP PRO GO.

Battery Enclosure Dimensions

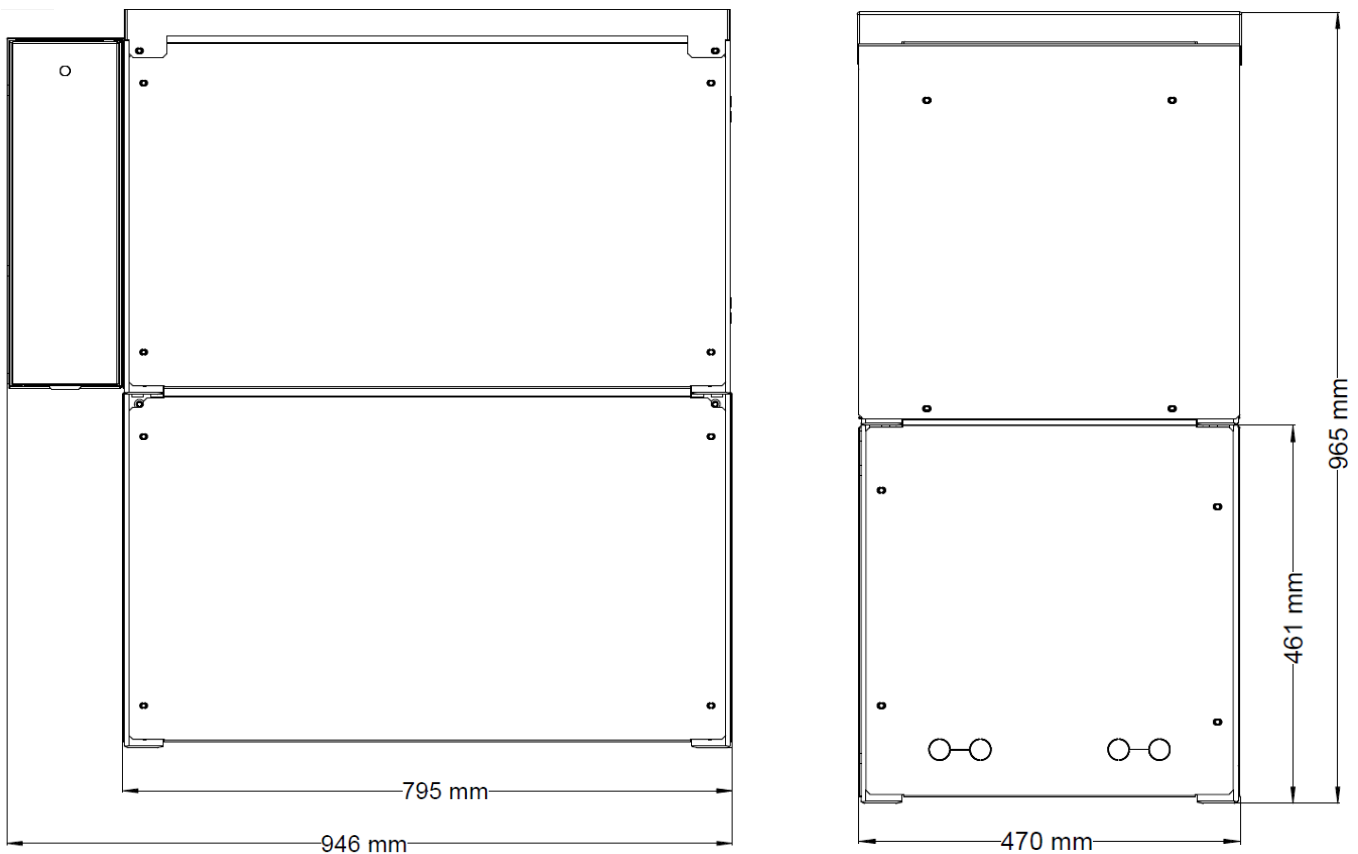

Dual Frame Enclosure shown.
 Quad Frame enclosure is twice the width.
 Single Frame Enclosure is half the height.

No minimum spacing is required either side of the battery enclosure. All maintenance access is from the front and top.



CHOOSING MANAGED CIRCUITS

When installing a myGrid kit in a Solar Hybrid system rewiring of the installations AC switchboard may be required to split out the load circuits that need to be managed.

If all the installation's load circuits total less than 63 amps (the SP PRO OR SP PRO GO's feed through capacity) it may be easiest to make all the load circuits (excluding off peak loads like hot water) managed. This provides energy management of all the house loads via SP LINK however the customer may need to manually manage the loads during a grid outage to prevent a system overload.

PLACEMENT OF SP PRO OR SP PRO GO

The SP PRO or SP PRO GO needs to be mounted with sufficient clearance on all sides with allowance for air flow and cabling. See SP PRO or SP PRO GO Instruction Manual for full details.

ADDITIONAL PARTS TO BE SUPPLIED

Some additional parts are required to be supplied by the installer.

- AC Cabling – sized to suit maximum AC demand of AC Loads and charging capacity.
- 25mm Conduit
- Mounting hardware
- Solar panels, Grid Inverter, cabling and isolators – as required

KIT CONTENTS

- Battery enclosure metalwork components
- Pre-assembled and wired DC switchbox
- Screws for assembly of the battery box
- Insulated Ring Spanner to tighten battery clamps
- Torx bits to suit screws provided
- DC battery cables
- DC battery sense cables
- Pre-assembled Battery interconnects
- Selectronic SP PRO or SP PRO GO interactive inverter
- Sonnenschein 330AH 6V Gel batteries



Assemble Battery Enclosure – Part A

The kits are shipped ready to be assembled. Each kit comes with the required number of frames to suit the number of batteries supplied.

The battery enclosure is modular for ease of assembly and versatility. Each frame is individually assembled before all the assembled frames are bolted together to form the battery enclosure.

ASSEMBLE FRAMES

Each frame supplied must be assembled.

Install Frame Vents

Frame vents are installed into the bottom shelf frame(s) only.

NOTE: Frame vents are packed with the battery enclosure lid(s).

- Place the Frame Vent on the shelf support angle and move in the direction shown in Figure 1 until it contacts the inserts on the front and back faces of the frame.
- Rotate the top of the Frame Vent in the direction shown in Figure 2 and push it down into the gap between the frame bracket verticals and the shelf support.
- Secure the Frame Vent to the shelf support using M4 x 12mm long screws (2 off) supplied as shown in Figure 3.

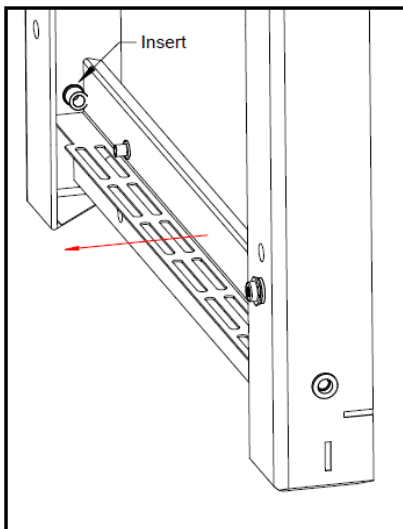

Figure 1

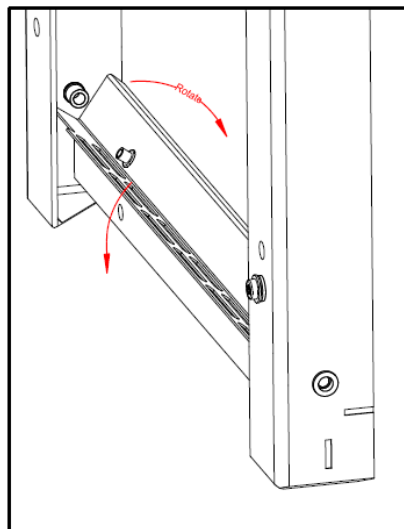

Figure 2

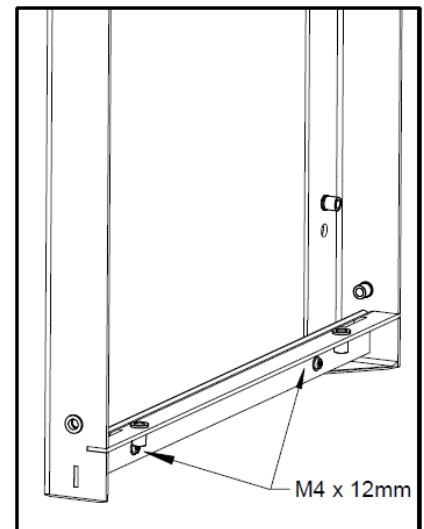

Figure 3



Install Shelves into Frames

- Place the Shelf on to the frame brackets so that the inner face of the upward fold is flush with the inner faces of the frame brackets as shown in Figure 4.
NOTE: Both Left and Right frames brackets are identical.
- Secure in place using M6 x 16mm screws (4 off) supplied.

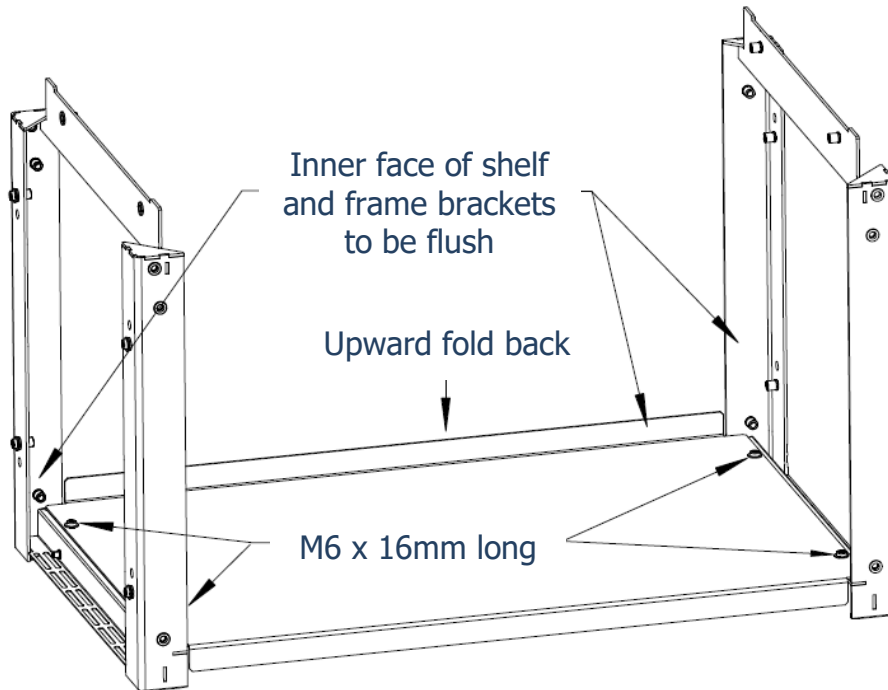

Figure 4

Install Rear Cover to Frames

- Locate the Rear Cover (with knockouts) onto the Frames as shown in Figure 5
- Secure in place using the M6 x 16mm long screws (4 off) supplied.

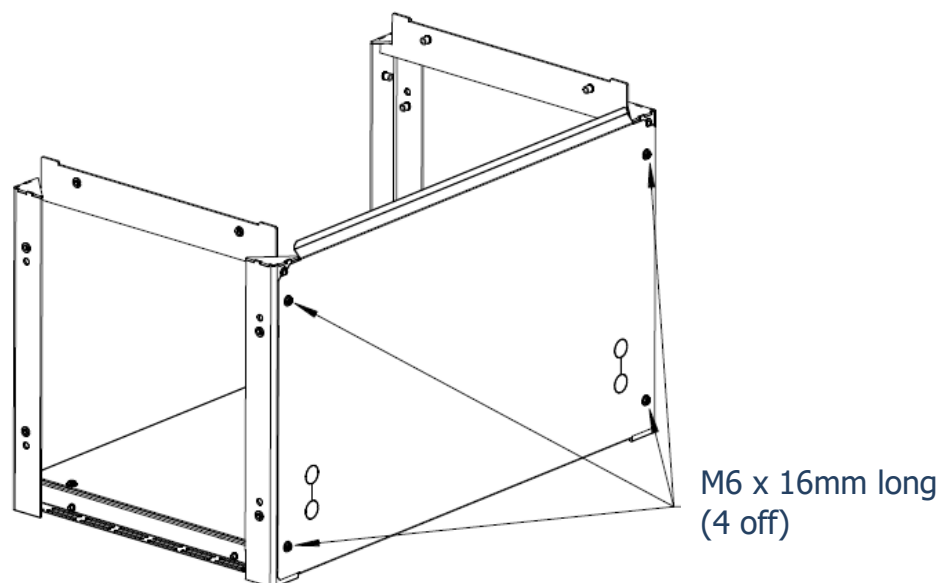

Figure 5



ASSEMBLE FRAMES INTO THE ENCLOSURE

The frames are assembled together to form the complete battery box.

Single Frame – skip next step

Dual Frame – assemble one frame on top off the other

Quad Frame – assemble two Dual Frames side by side

Five Frames – add one additional frame on top of a Quad frame.

Ten Frames – five dual frames side by side.

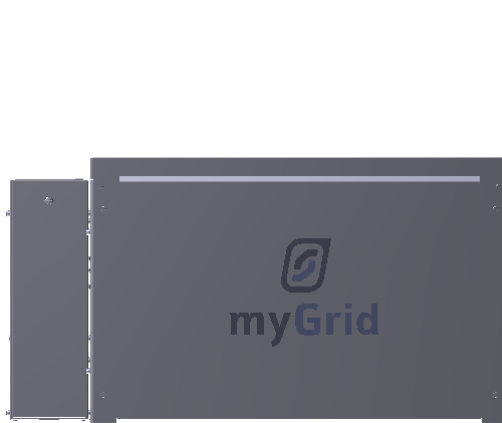

Single Frame

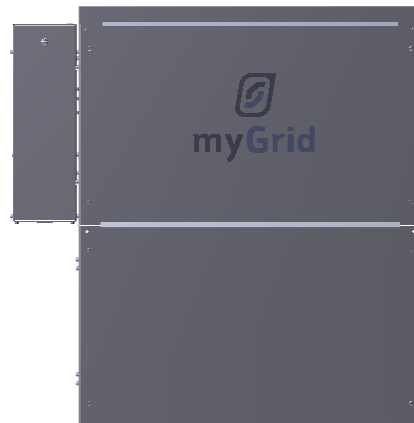

Dual Frame

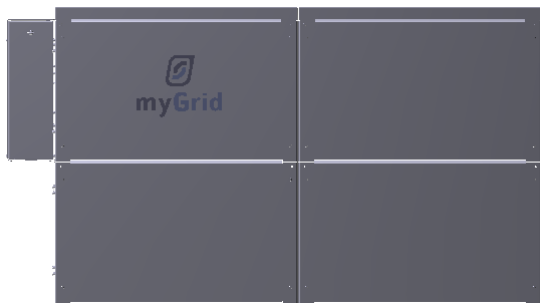

Quad Frame

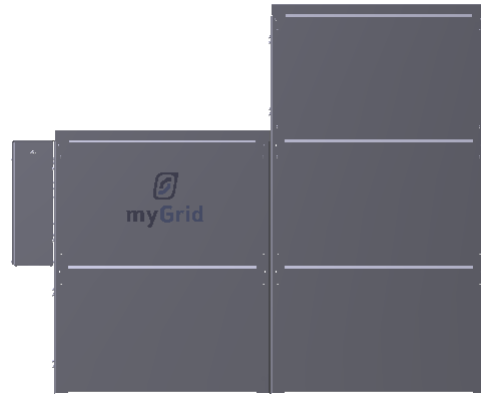

Five Frame



Dual Frame Assembly

- Place the frame assemblies together as shown in Figure 6. Frames with vents to be at the bottom of the assembly.
- Secure to each other using the M6 x 16mm long screws (2 off per side) supplied as shown in Figure 6.

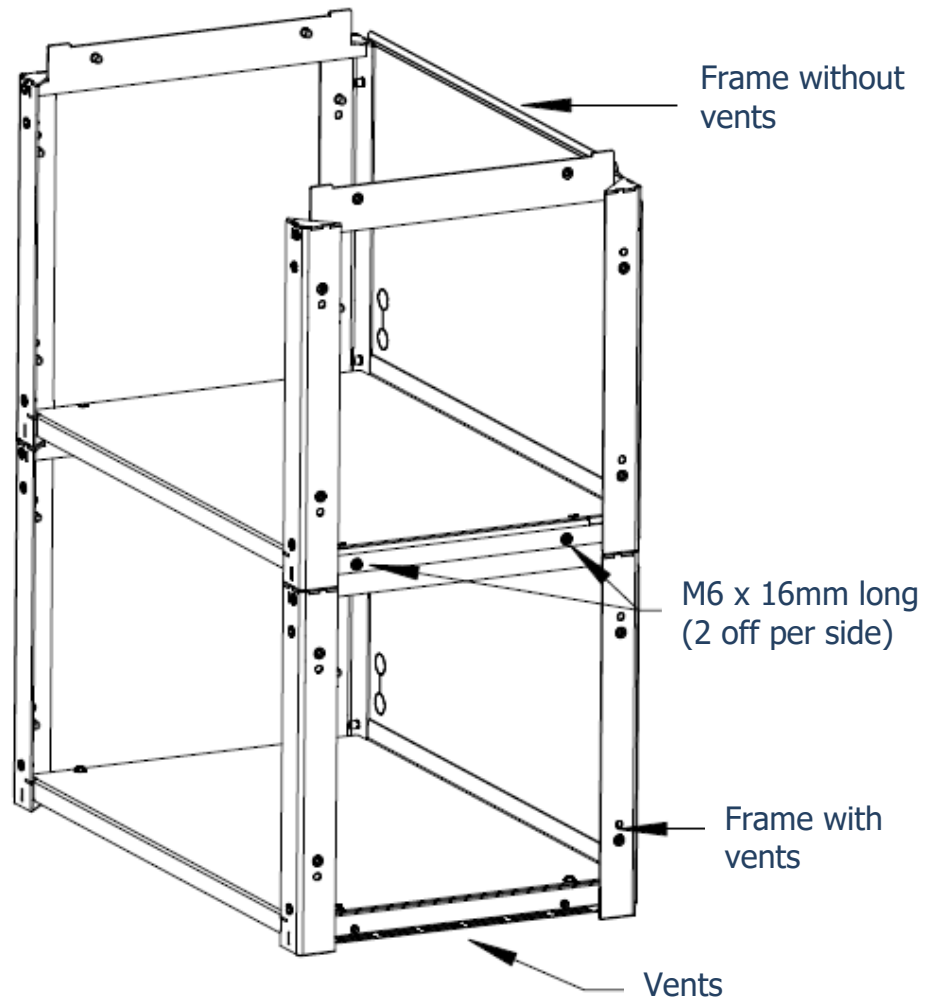

Figure 6



Quad Frame Assembly

- Place the frame assemblies together as shown in Figure 7. Ensure the frames with vents are at the bottom.
- Secure frame to frame using the M6 x 16mm screws supplied (4 screws per frame).

M6 x 16mm long (4 off)
on each row of frames

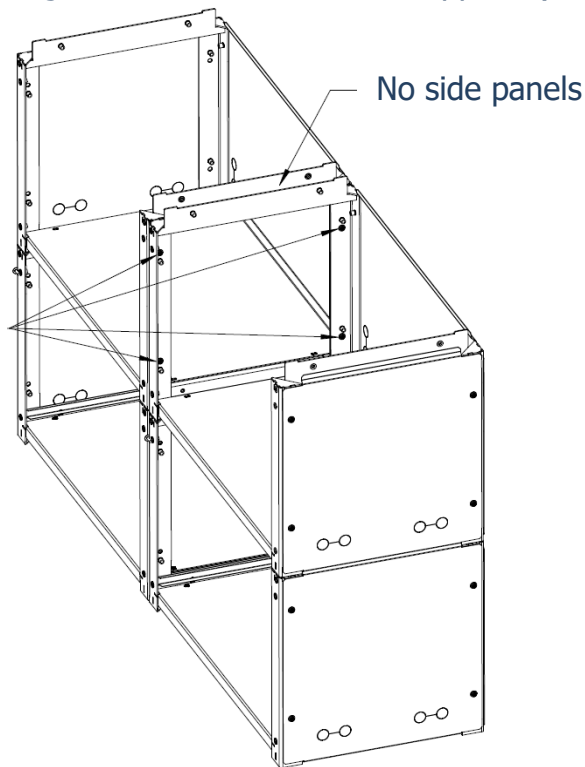

Figure 7

FIT DC SWITCHBOX

The DC Switchbox is fitted to the side of the battery enclosure. The DC Switchbox comes ready to be fitted to the left hand side of the battery enclosure but may be changed to mount on the right hand side – see Appendix B for details.

- Remove the Main and Front covers from the DC Switchbox assembly.

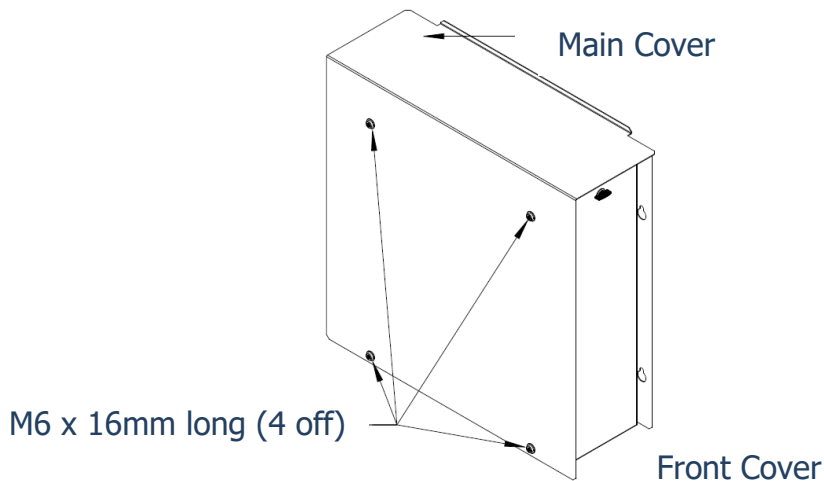

Figure 8



- Insert M6 x 16mm long screws (4 off) into the Battery Frame inserts leaving 3 to 5mm between the screw head and the frame insert. - Refer to enlarged view in Figure 9.
- Pass the large holes of the DC Switchbox over the screw heads and allow it to drop onto the screw threads and tighten screws.

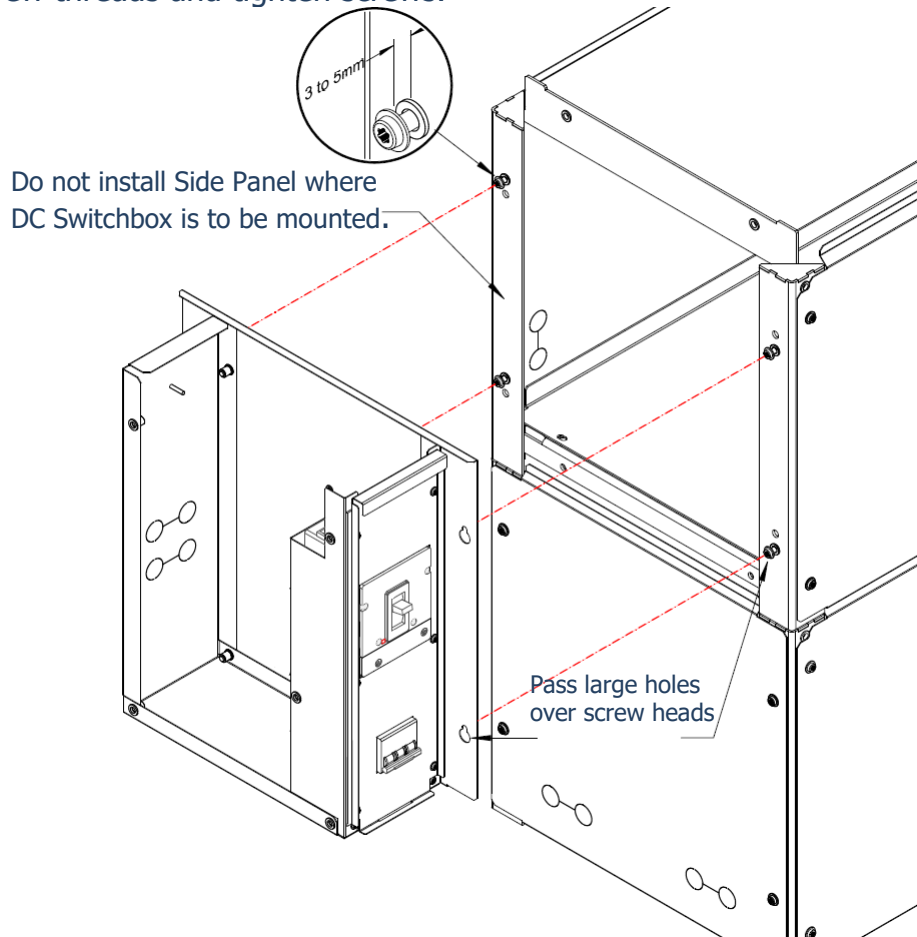

Figure 9

PLACE INTERLINK CABLES

Place into position the DC switchbox battery cables and battery interlink cables that run between different levels within the battery enclosure. These cables run in the gap between the frame brackets and the side plates. They are marked **(A)** on the applicable Battery Connections Diagrams and need to be positioned before the side panels are fitted.

FIT SIDE PANELS

Locate the side panels on the frames and secure using the M6 x 16mm screws supplied (4 per panel) except where DC Switchbox is fitted.

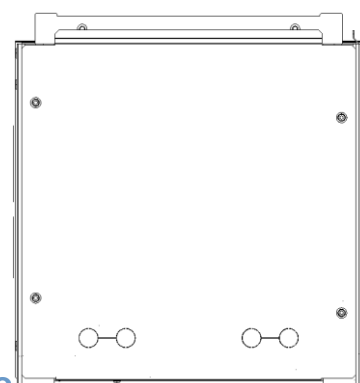

Figure 10



FIT TOP COVERS

Locate the Top Cover on the frames so that it overhangs at the rear and the front of the cover is resting on the front edges of the frames as shown in Figure 11a.

Move the cover towards the front of the frames to engage the pins on the inside rear of the cover into the inserts in the frames.

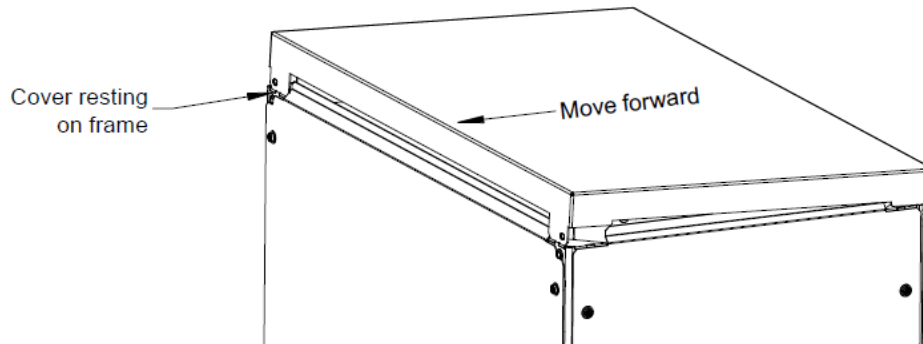

Figure 11a

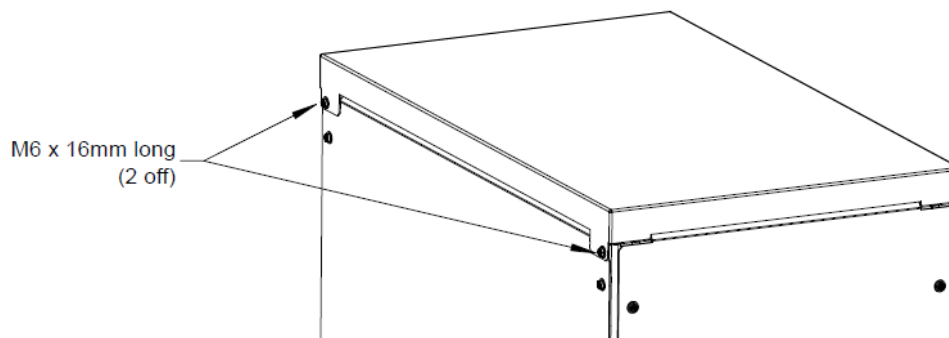

Figure 11b

Lower the cover and secure it to the frames using M6 x 16mm long screws (2 off). Refer to Figure 11b.

Position Battery Enclosure

Battery enclosure is now suitably assembled to be positioned. The battery enclosure (once fitted with batteries) is quite heavy and must be placed on a solid surface - if to be placed on dirt then using concrete squares for each leg is suitable. Ensure all legs are supported upon a solid surface and the battery enclosure is level (use a spirit level to ensure battery enclosure is level side to side and front to back).

Adequate ventilation is required. Air is drawn in from below each side panel and vented out at the top of the front side panel.

Batteries are degraded by high temperature. Enclosure is to be placed in coolest position and **MUST** be protected from direct sunlight.

Cable entry is provided at the rear of the DC Switchbox. Position the battery enclosure to minimise cable length to the SP PRO or SP PRO GO via most appropriate cable entry point either below or from behind.



Installing the SP PRO OR SP PRO GO

Install the SP PRO or SP PRO GO as per the installation instructions.

Verify the position of the battery enclosure is suitable for the supplied length of DC cabling. Reposition the Battery enclosure or inverter as appropriate.

CABLING

Tools – 6mm hex bit, supplied with the SP PRO or SP PRO GO inverter.

Parts – 25mm Flexible Conduit

Use the following diagram as a guide to install DC cabling.

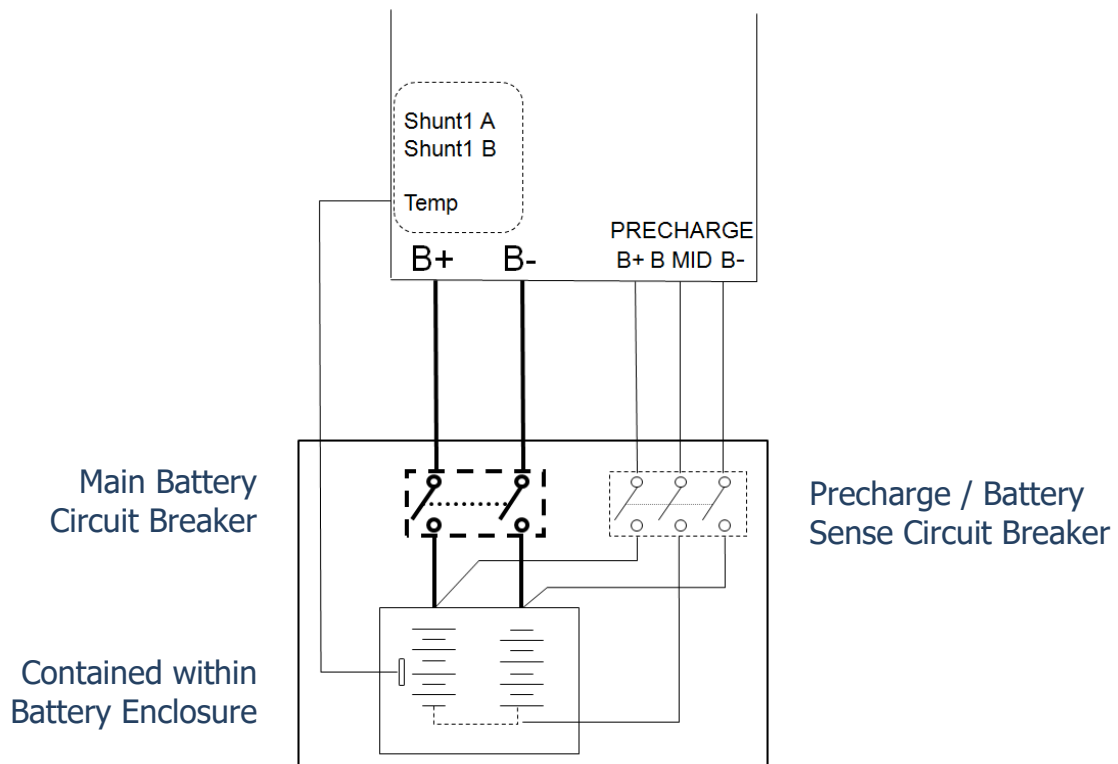

The DC cables are pre-terminated within the DC Switchbox. The cabling is listed in order to enable easy installation and routing of DC cables –

1. DC Sense and Temperature
2. Battery Negative
3. Battery Positive

DC CABLE KNOCKOUTS

Knockout three of the four 25mm gland holes;
 one for battery positive,
 one for battery negative and
 one for battery sense and temperature cables
 and fit off with conduit glands.



BATTERY SENSE CABLING AND BATTERY TEMPERATURE SENSE

Disconnect the battery temperature sensor cable from the SP PRO or SP PRO GO expansion card and feed it through with the Precharge / Battery Sense cable (end without M10 Ring lugs) from DC Switchbox to the SP PRO or SP PRO GO via conduit and glands.

Strip Precharge / Battery Sense cable to bear each lead and connect into the terminals as indicated –

B+ : Brown
B MID : Yellow
B- : White

Note: Take care to observe minimum strip lengths.

Reconnect the battery temperature sensor cable to the expansion card as indicated –

SUPPLY : Grey
BATT TEMP : Grey

Note: Temperature sensor is not polarity sensitive and can be connected either way.

MAIN BATTERY CABLING

Feed Black B- cable (without battery lug) from DC Switchbox to the SP PRO or SP PRO GO directly below the B- terminal via conduit and glands.

Feed Red B+ cable (without battery lug) from DC Switchbox into the SP PRO or SP PRO GO directly below the B+ terminal via conduit and glands.

Remove the pre stripped insulation and connect into the terminals as indicated –

B+ : Red
B- : Black

Note: Take care to ensure all strands go into the clamp terminals.



Installing the Batteries

Warning: Batteries are very dangerous. Battery fault currents are 1,000s of amps. Please read and adhere to the safety information provided with the batteries.

Safe practices when working with battery systems –

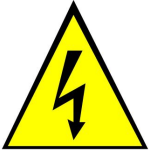

- Remove all conductive jewellery or watches before working on batteries.
- Keep any conductive tools well clear of the batteries
- Only use non-conductive or insulated tools when working on or near the batteries.
- Double check the connection orientation of the batteries and battery links.
- Before connecting any links between battery terminals, check the voltage between those battery terminals to be zero using a volt meter.
- Care **MUST** be taken when connecting the battery interlinks. Please note that the loose end of the battery interlink is live and must be prevented from shorting to other batteries or battery terminals.

NOTE: Ensure Main Battery and Pre-charge/Battery Sense circuit breakers are in the O / Off position before making any connections to the batteries.

BATTERY TERMINAL SIZE

The battery positive terminal is larger than the battery negative terminal. It is important to ensure that only a RED coloured clamp is fitted to a battery positive terminal and the BLACK smaller clamp is fitted to a battery negative terminal.

BATTERY INTERCONNECTS

The supplied battery interconnects have been pre-assembled, tightened and designed to suit the battery configurations pictured below. There is no need to loosen any of the pre-assembled battery interconnects. Adjust the position of the batteries by sliding them to fit rather than adjusting the battery interconnects.

Battery Link

Used for connecting two batteries in series – battery positive to battery negative.





Battery Interlink – Parallel

Used to series connect between frames of two groups of parallel batteries – two groups of battery positive to two groups of battery negative.

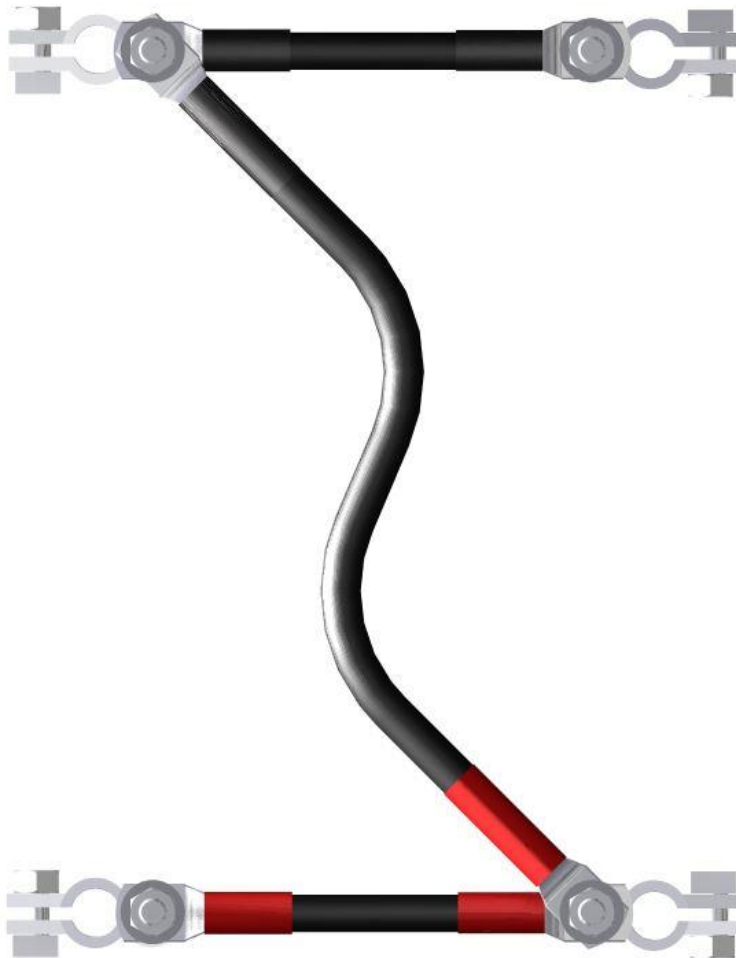

Battery Interlink – Series

Used to series connect between frames - battery positive to battery negative.





Battery Clamps

The battery G-Clamps lock onto the terminals using an Insulated Ring Spanner. Ensure the nut is loosened so that the clamps can be comfortably seated onto the terminals as shown below –

Battery Positive and Negative G-Clamps shown in clear position ready to go onto battery terminal



NOTE: Make sure both the Positive and Negative G-Clamps are connected to the correct terminals as indicated above.

Tightly fit the G-Clamps onto the battery terminals by gently tapping the clamps onto the battery post. Proceed to hand tightening the nut using a ring spanner until there is no motion in the clamp. Finally confirm that the clamp is locked onto the battery terminal by ensuring minimal movement on the clamps.

RED Battery Positive and BLACK Battery Negative Clamps shown fully seated and locked onto terminal.

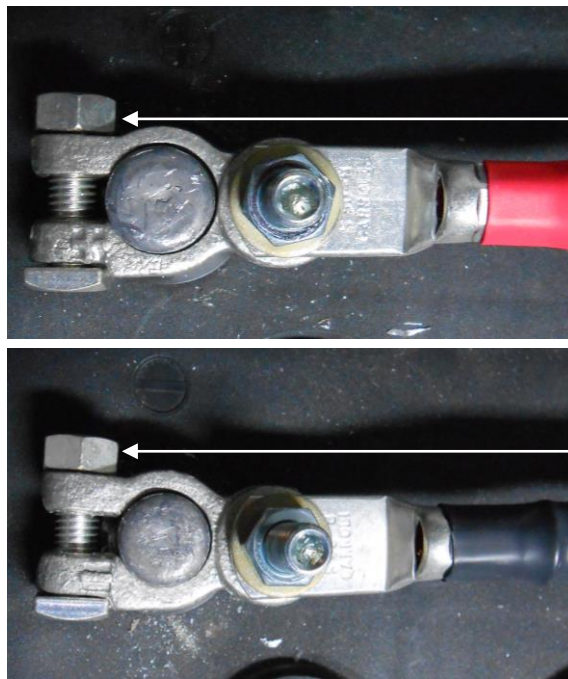

Tighten the clamp using Insulated Ring Spanner



BATTERY SENSE CABLING CONNECTIONS TO THE BATTERIES

The battery sense wires are connected to the batteries after the battery clamps have been fitted and locked into place and before installing the next shelf of batteries.

Fit the battery sense connections onto the studs of the associated battery connection and lock in place with one of the 8mm lock nuts (skinny nuts) provided. The connection points of each of the three battery sense cables are shown on the battery connection diagrams on the following pages.



NOTE: The outer sheath of the battery sense cable will need to be stripped back to enable the connections to reach in some of the battery configurations.

BATTERY POSITIONING

The battery frames will accept 4 batteries each. Batteries can be slid into the enclosure from the front.

Always install batteries into the lowest frame first with the shelf or lid above removed. Make all battery interconnections and then fit shelf above or the top cover.

Repeat for shelf above as applicable.

Batteries should be placed according to the diagrams below taking careful note of battery positive and negative positioning.

Note: The diagrams show the battery positions for DC Switchbox mounted on the left hand side.

PARALLEL BATTERY CONNECTIONS

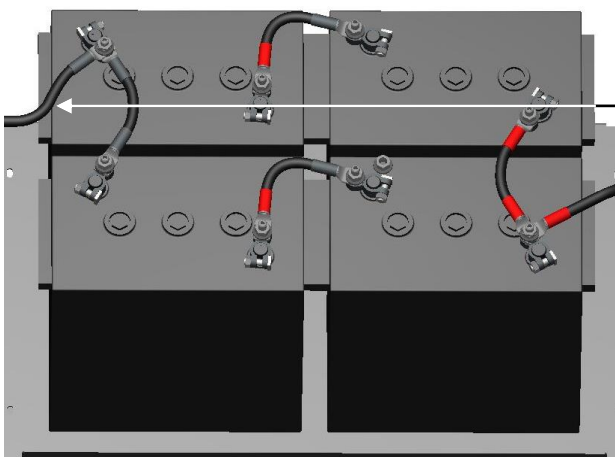

Note: For Parallel battery connections ensure that battery clamps are positioned such that the lead in and the lead out are in opposite corners of the battery cluster. This will ensure equal current sharing through the parallel strings.



BATTERY CONNECTIONS

myGrid 24 VDC 8 kWh Battery Connections

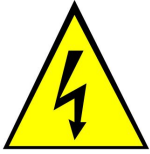

Warning: Ensure Main Battery and Precharge Circuit breakers are 0 / Off position.
NOTE: Battery fault currents are 3,970 amps

Battery Sense -ve (White)

Battery Sense Mid (Yellow)

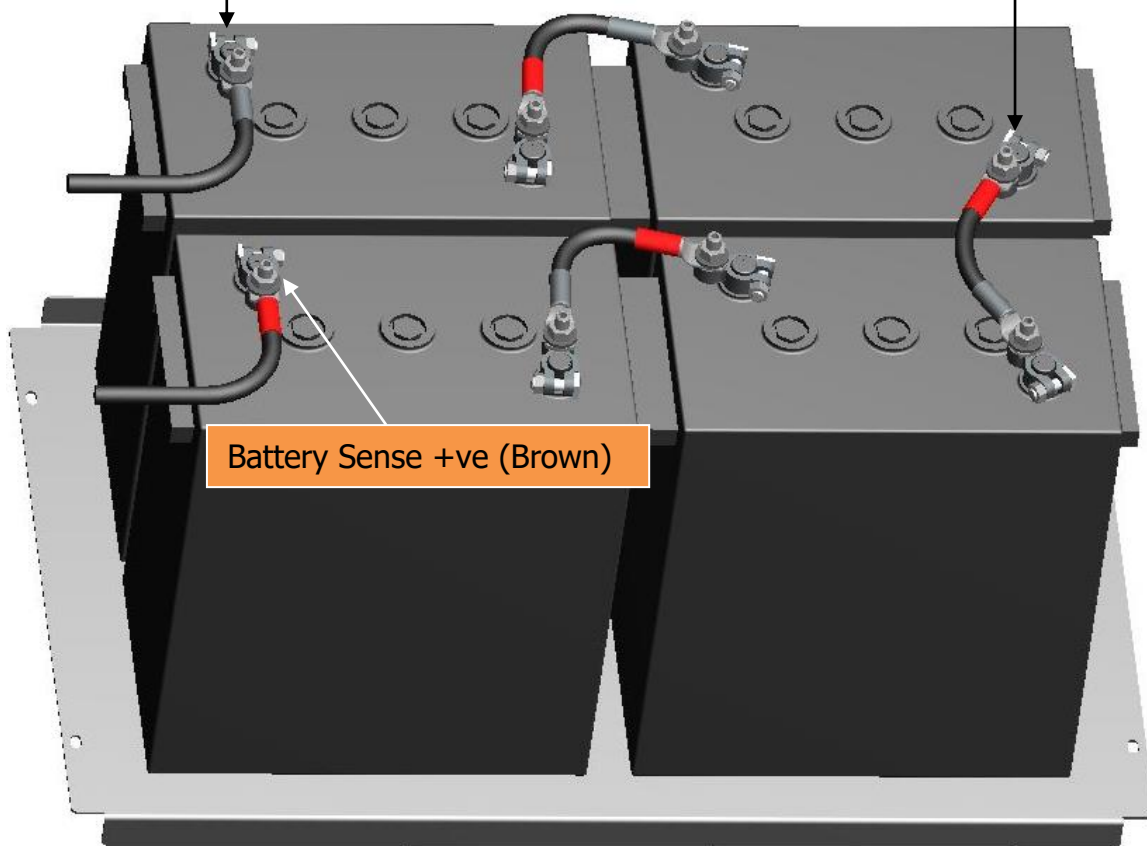

Battery Sense +ve (Brown)

4 x 330 Ah 6 V Batteries in series
Frame – One 24 VDC group made up of four series 6 VDC batteries.
Ensure batteries are placed with the positive and negative terminals as shown.



myGrid 24 VDC 16 kWh Battery Connections

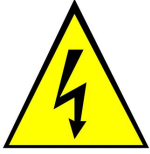

Warning: Ensure Main Battery and Precharge Circuit breakers are 0 / Off position.
NOTE: Battery fault currents are 7,940 amps

Battery Sense -ve (White)

Battery Sense Mid (Yellow)

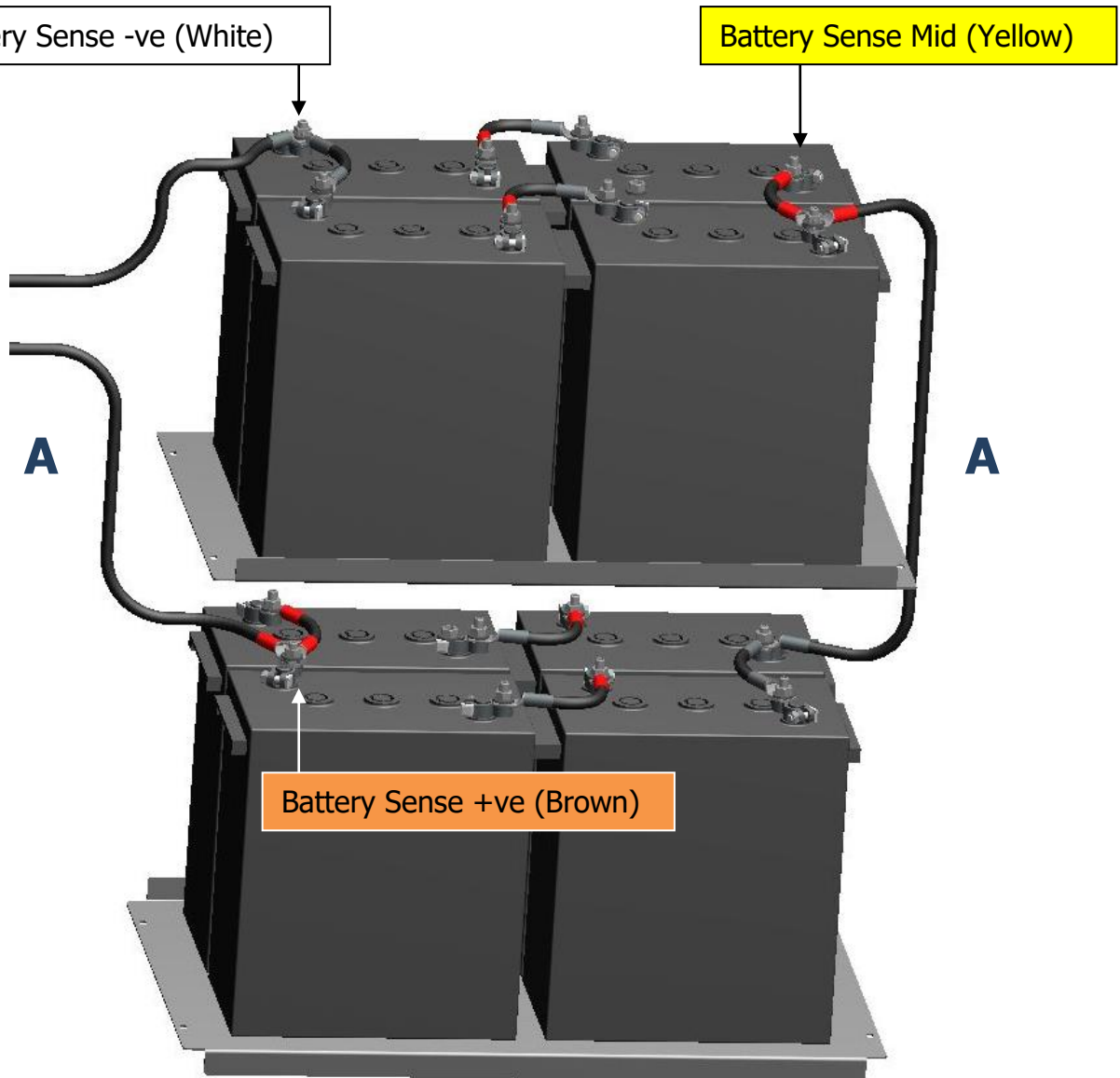

8 x 330 Ah 6 VDC blocks in parallel / series combination
Each frame – Two parallel 12 VDC groups made up of two series 6 VDC batteries.
Ensure batteries are placed with the positive and negative terminals as shown.



myGrid 48 VDC 16 kWh Battery Connections

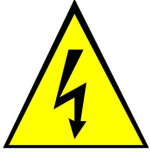

Warning: Ensure Main Battery and Precharge Circuit breakers are 0 / Off position.
NOTE: Battery fault currents are 3,970 amps

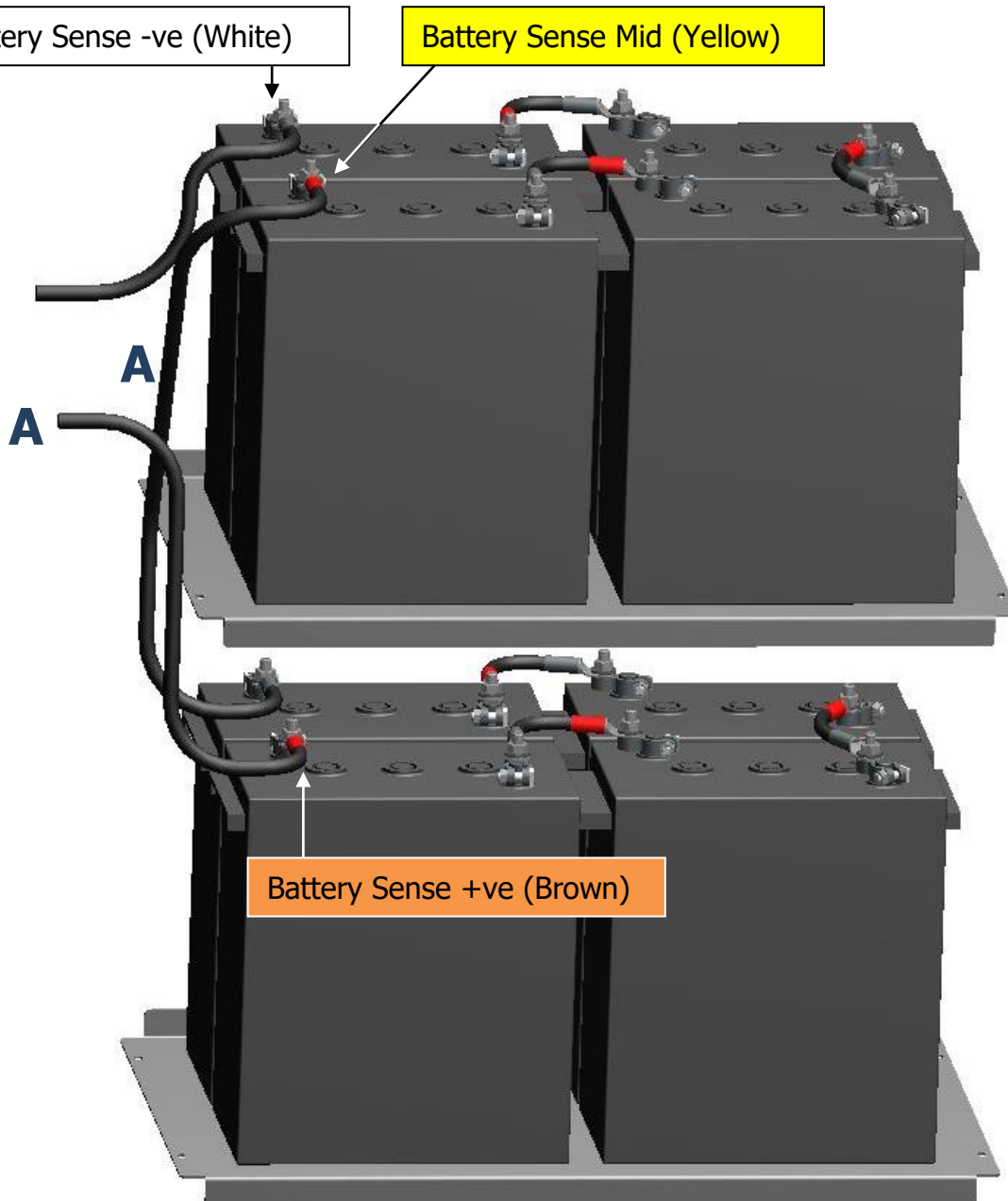

8 x 330 Ah 6 VDC blocks in series combination
Each frame – One 24 VDC group made up of four series 6 VDC batteries.



myGrid 48 VDC 32 kWh Battery Connections

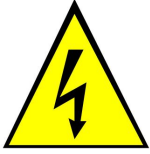

Warning: Ensure Main Battery and Precharge Circuit breakers are 0 / Off position.
NOTE: Battery fault currents are 7,940 amps

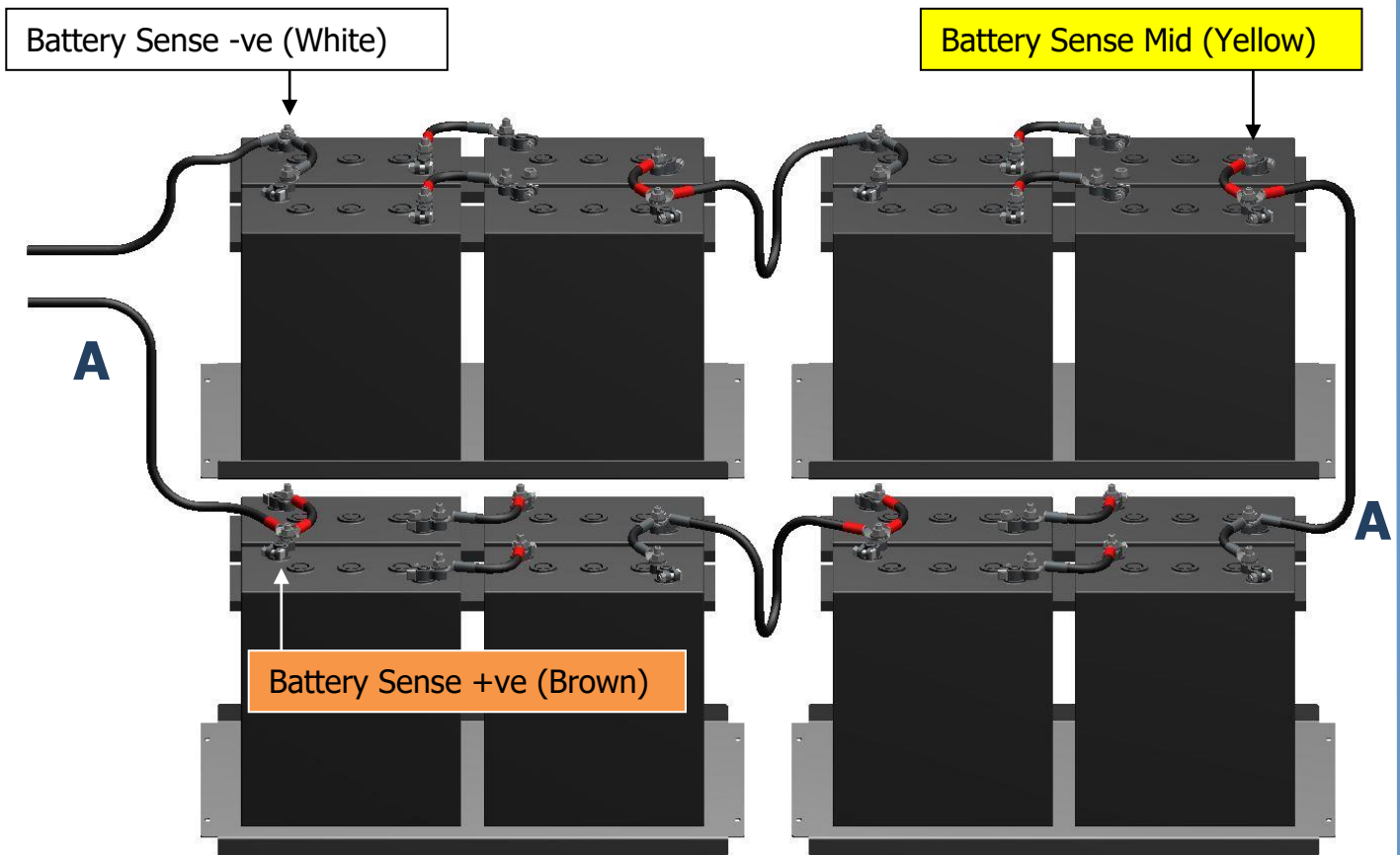

16 x 330 Ah 6 VDC blocks in parallel / series combination
Each frame –Two parallel 12 VDC groups made up of two series 6 VDC batteries.



myGrid 120 VDC 40kWh Battery Connections

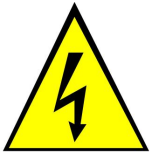

Warning: Ensure Main Battery and Precharge Circuit breakers are 0 / Off position.
NOTE: Battery fault currents are 3,970 amps

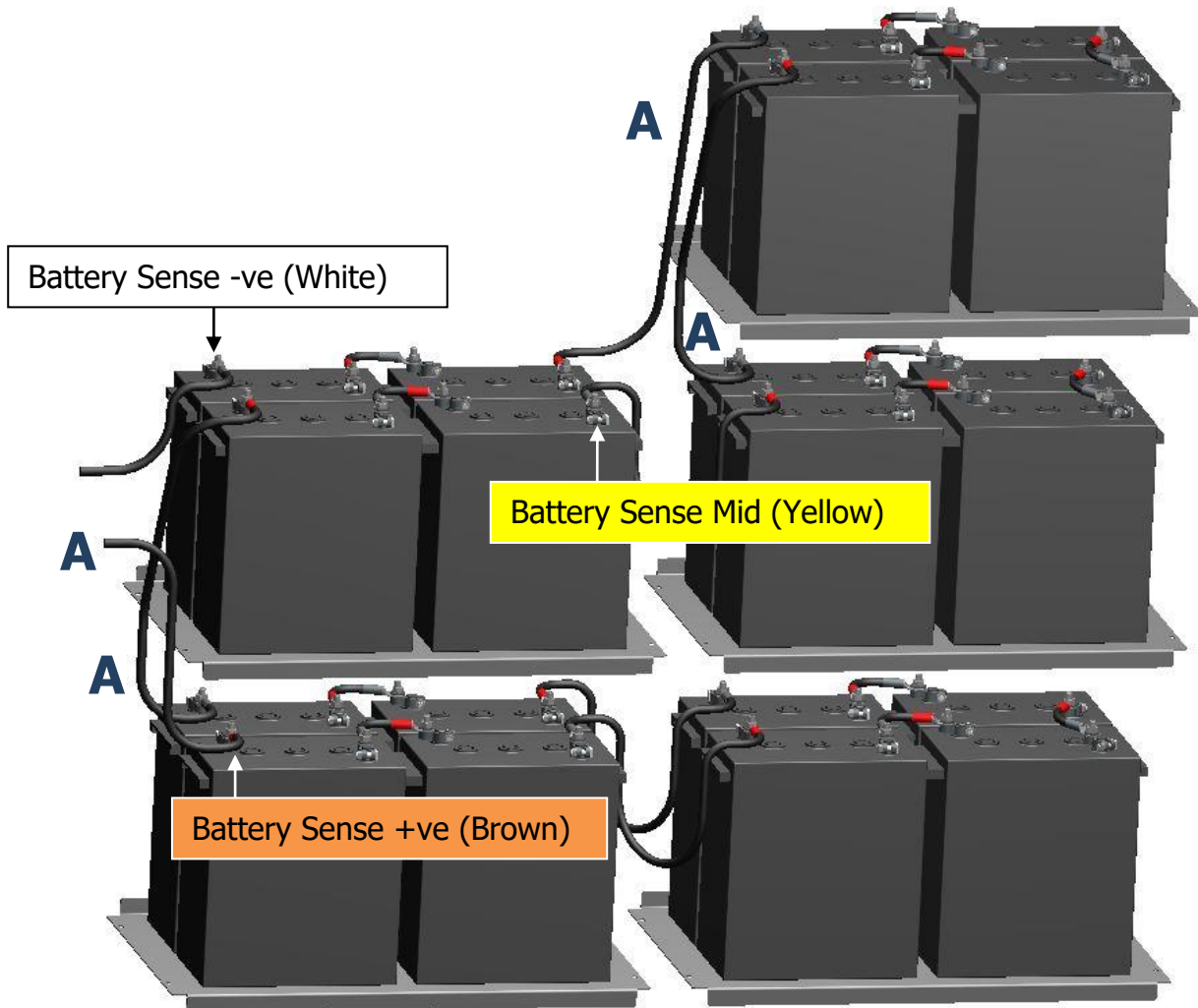

20 x 330 Ah 6 VDC blocks in series combination
Right Hand Frames – One 24 VDC group made up of four series 6 VDC batteries.
Left Hand Frames – Two groups of 12 VDC made up of two series 6 VDC batteries.



myGrid 120 VDC 80kWh Battery Connections

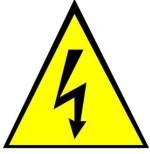

Warning: Ensure Main Battery and Precharge Circuit breakers are 0 / Off position.
NOTE: Battery fault currents are 7,940 amps

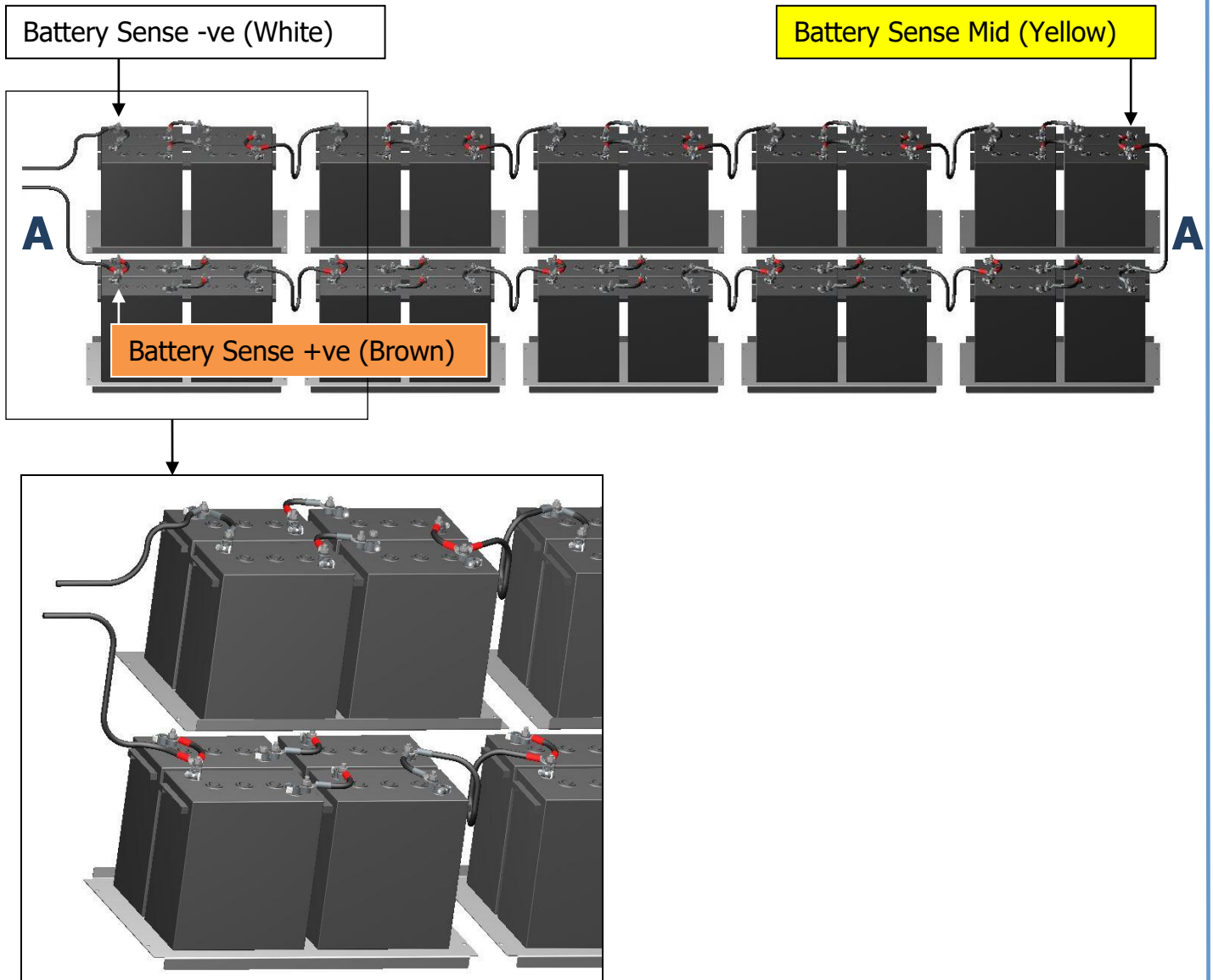

40 x 330 Ah 6 VDC blocks in parallel / series combination
Each frame – Two parallel 12 VDC groups made up of two series 6 VDC batteries.



AC CABLING

Use the following diagram as a guide to install AC cabling into the existing AC Switchboard. Refer to SP PRO installation Manual for further information.

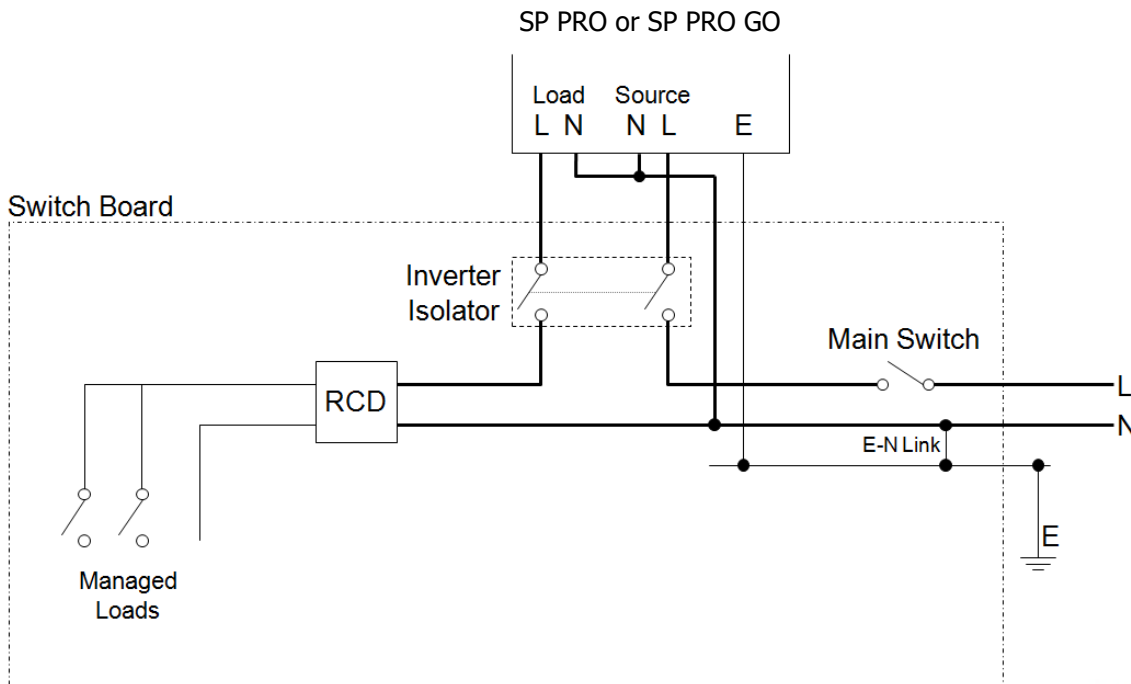

PRE-POWER ON CHECK



Before the final assembly of the covers on the battery box the Pre-Power on Check list MUST be filled out – See Appendix A

FINAL BATTERY BOX ASSEMBLY

Fit all of the front panels (plain panels without knockouts) to the battery enclosure using the M6 x 16 screws supplied (4 off per panel).

Fit the DC switchbox main cover using the M6 x 16 screws supplied (4 off)

Fit the battery enclosure Lids and secure with the M6 x 16mm screws supplied (2 off)

Fit the DC switchbox front cover.

SIGNAGE

Signage applicable to the myGrid system has been included at the end of this manual

1. Spark Hazard warning. One sign for each configuration. Please select the sign applicable to your myGrid configuration.
2. Shutdown procedure for myGrid.

Additional Information

Selectronic web site – <http://www.selectronic.com.au> or contact the Selectronic Sales Team.



CONFIGURATION FILES AND CHARGING PROFILE TO SUIT BATTERIES.

Using the Quick Start Wizard found in the SP LINK software (Revision 7.7 and above), configure the SP PRO inverter to suit the myGrid kit and application parameters. The correct myGrid kit can be selected in the Quick Start Wizard along with other system parameters to automatically create a suitable Site File and Configuration File for the SP PRO inverter. Any advanced settings can then be configured before programming the SP PRO via the "Configure SP PRO" button.

The Quick Start Wizard window consists of three options, select the Site Configuration Wizard in the start-up window and step through the configuration process to setup the appropriate parameters.

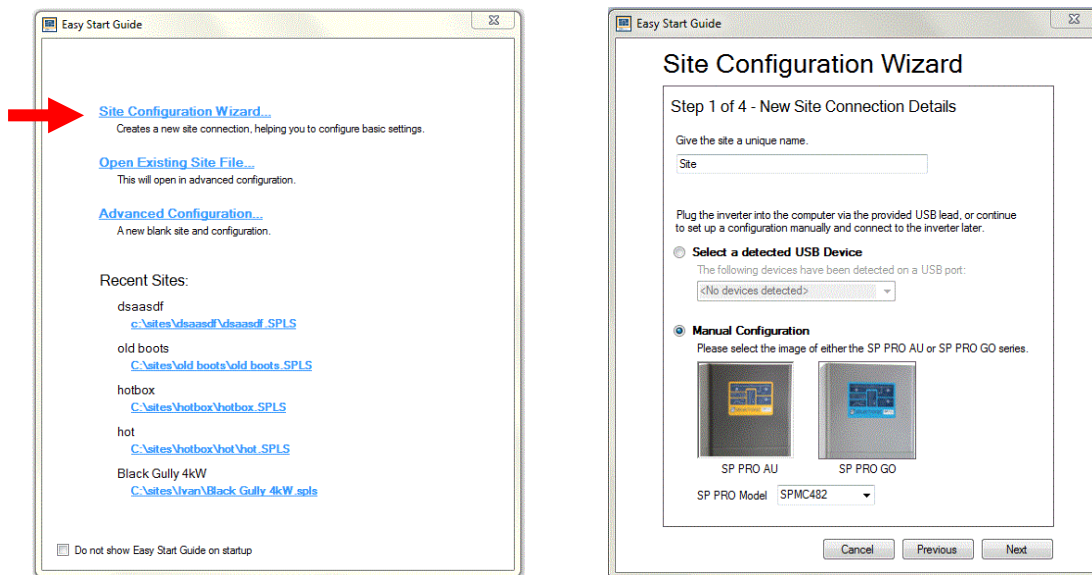

See SP LINK manual, found in the SP LINK program, for further information on configuring the SP PRO.

FULLY CHARGE AND EQUALISE BATTERY BANK

It is highly recommended that the battery bank be put through a full charge and equalise charge cycle before the myGrid system goes into service. This can be done by changing the charger' equalise state to "Equalise Pending" in the "Service Settings menu in SP LINK.

SIGNAGE

Signage applicable to the myGrid system has been included at the end of this manual

1. Spark Hazard warning. One sign for each configuration. Please select the sign applicable to your myGrid configuration.
2. Shutdown procedure for myGrid.



Warranty

Metal Work and Cables:

When fitted in accordance with these instructions, the metal work, cables and switches are warranted for a period of 5 years from date of purchase.

Batteries:

The batteries carry the original manufacturer warranty at time of purchase, which at time of publishing was 12 months with Pro rata warranty for five years from date of shipment. Contact GNB Industrial Power for full warranty details for Sonnenschein SB6/330 330AH 6V Gel batteries.

Additional Information

Selectronic web site – <http://www.selectronic.com.au> or contact the Selectronic Sales Team.



Appendix A

PRE-POWER ON CHECK LIST

Items to be checked	Checked OK
Check all battery clamps are fully seated home	
Check all battery clamps are locked down	
Check battery sense connections are correct	
Use a meter to check the voltage and polarity of the main battery connections on the battery (Red is +ve and Black is -ve).	
Check that the current is set to 250A on the main 250A DC breaker.	
Use a meter to check the voltage and polarity of the battery sense connections on the battery (brown is +ve and white is -ve).	
Use a meter to check the voltage and polarity of the mid-point connections on the battery– (white is -ve and yellow is +v). This should be half the battery voltage.	
Recheck the DC battery cable wiring into the SP PRO or SP PRO GO to ensure terminals are tight.	
Recheck the DC battery cable wiring into the SP PRO or SP PRO GO to ensure insulation is not clamped into terminal.	
Recheck the DC battery cable wiring into the SP PRO or SP PRO GO for correct polarity	
Recheck the DC battery sense cable wiring into the SP PRO or SP PRO GO for correct polarity	
Carry out a Cable Loss check – see below	



CABLE LOSS CHECK

Power up inverter with the AC source turned off. Apply a load of at least 2kW to the inverter and check the "Cable Loss" reading (see below) to be less than 1% of load power for a 24V system and less than 0.5% of load power for a 48V systems.

File	Connection	Performance Data	Help	Connected	00:00:24	04/09/2013 - 17:10:10
Site Information	Configuration Settings	QuickView	Data View	Service Settings		
Now	Today	DC History	AC History	Technical Data	Expansion Card Wiring Diagram	

Inverter		Component Life		Battery	
SP PRO Model	Power Module 1 Serial Number	Power Module 1 Capacitor Life	Charging Mode	Days to Recharge	
SPMC481-AU	90044	0.5 %	Long Term Float	25	
SP PRO Ratings	Power Module 1 Revision	Power Module 2 Capacitor Life	Charge Eff. Index	Days Since Recharge	
48V DC, 5kW, 240V AC	3	0.5 %	0.886	3	
SP PRO Serial Number	Power Module 1 Mod Status	Fan Life	Days to Equalise		
94129		0.0 %	Disabled		
SP PRO Revision	Power Module 2 Serial Number	(Component Life: component's rated life consumed so far)	Days Since Equalise		
20	90040		4		
SP PRO Mod Status	Power Module 2 Revision		Sense Voltage		
	3		53.5 V		
Software Version	Power Module 2 Mod Status		DC Inverter Voltage		
6.27			53.5 V		
Control PCA Serial Number	SP PRO Total Run Time		Midpoint Voltage		
88900	20661.3 h		26.7 V		
Control PCA Revision	Grid Connect SW Version		Power		
6	2.00		0.03 kW		
Control PCA Mod Status			Cable Loss		
6			0 W		





Appendix B

DC SWITCHBOX – LEFT HAND TO RIGHT HAND

To change the mounting of DC Switchbox from mounting on the Left side to Right side of the Battery Enclosure -

- Remove the Main cover from the left hand side of the housing. (4 screws) - Figure A1
- Remove the Base from the right hand side of the housing.(5 screws) - Figure A2

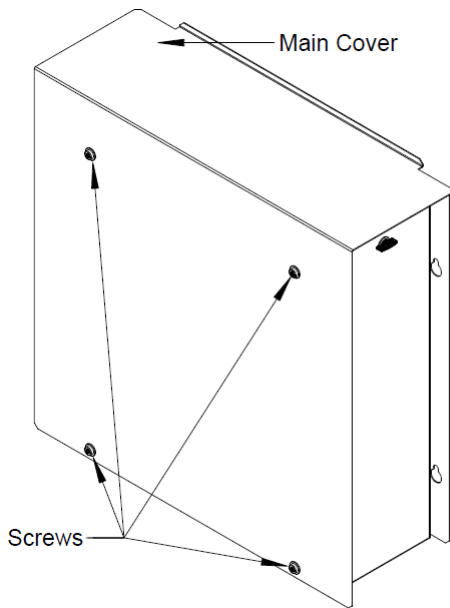

Figure A1

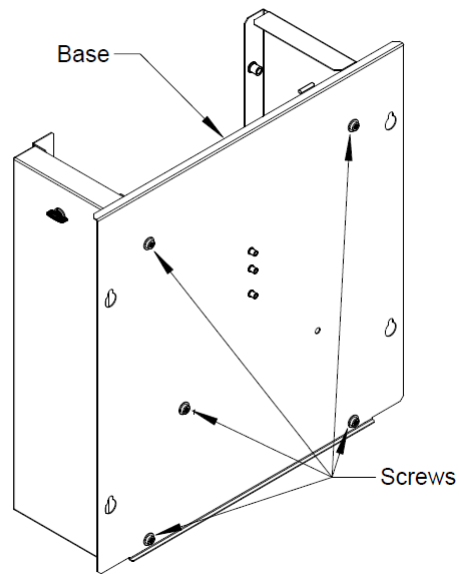

Figure A2

- Rotate the base 180° and secure to the left hand side of the housing. - Figure A3
- Place the Main cover onto the right hand side of the housing and secure in place. - Figure A4

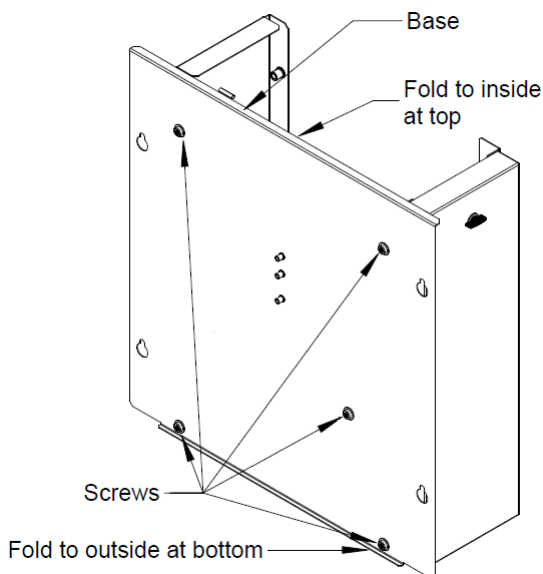

Figure A3

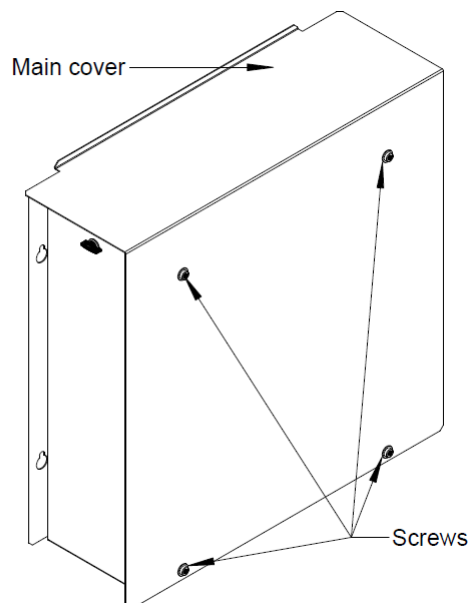



Figure A4

myGrid Shutdown Procedure

Shutdown Procedure

Step	Action		Result
1	<ul style="list-style-type: none">Press and hold ON button.		<ul style="list-style-type: none">Output Mode indicator is now OFF - Inverter is Idle and will not export or provide any backup supply.Charging Mode, Battery and Alarm indicators will remain On.Grid (if present) will continue to feed through to AC Load.
2	<p>Solar Isolating Main switch</p> <ul style="list-style-type: none">Switch OFF by pressing levers down.		<ul style="list-style-type: none">Solar is now isolated from system.
3	<p>Main Battery Circuit Breaker (under cover)</p> <ul style="list-style-type: none">Push handle firmly down into the Off (0) position.		
4	<p>Pre-charge / Battery Sense Isolator switch (under cover)</p> <ul style="list-style-type: none">Switch OFF by pressing levers down		<ul style="list-style-type: none">Inverter is now isolated from battery bank.Charging Mode, Battery and Alarm indicators will turn OFF.
5	<ul style="list-style-type: none">Switch OFF AC Isolator(s) – Source and Load		<ul style="list-style-type: none">AC Source, Transfer and AC Load indicators are now OFF. No supply to AC Load.Inverter is now isolated from grid supply.

Start up Procedure – Perform opposite action in reverse from 5 to 1.

Battery Bank

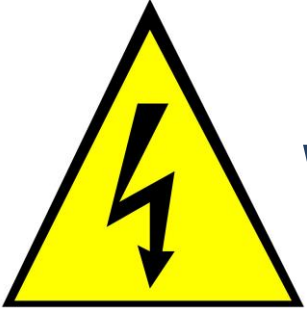

WARNING : SPARK HAZARD

Follow shutdown procedure before
connecting or disconnecting
any equipment.

Nominal BATTERY VOLTAGE - 24 Volts
Maximum FAULT CURRENT – 3,970 Amps

Battery Type: Sonnenschein SB6/330 A
(4 x 330 Ah 6V in series)

Battery Bank

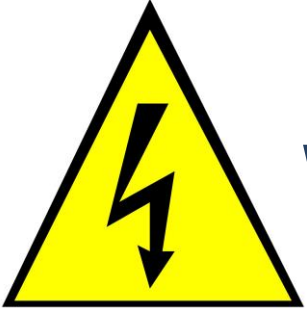

WARNING : SPARK HAZARD

Follow shutdown procedure before
connecting or disconnecting
any equipment.

Nominal BATTERY VOLTAGE - 24 Volts
Maximum FAULT CURRENT – 7,940 Amps

Battery Type: Sonnenschein SB6/330 A
(8 x 330 Ah 6V in series/parallel)

Battery Bank

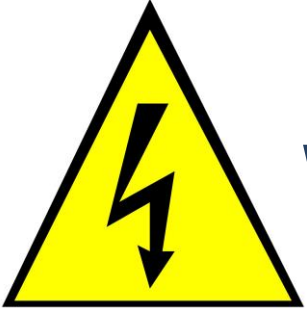

WARNING : SPARK HAZARD

Follow shutdown procedure before
connecting or disconnecting
any equipment.

Nominal BATTERY VOLTAGE - 48 Volts
Maximum FAULT CURRENT – 3,970 Amps

Battery Type: Sonnenschein SB6/330 A
(8 x 330 Ah 6V in series)

Battery Bank

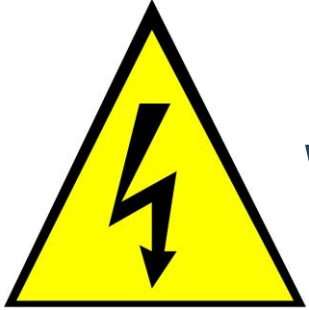

WARNING : SPARK HAZARD

Follow shutdown procedure before
connecting or disconnecting
any equipment.

Nominal BATTERY VOLTAGE - 48 Volts
Maximum FAULT CURRENT – 7,940Amps

Battery Type: Sonnenschein SB6/330 A
(16 x 330 Ah 6V in series/parallel)

Battery Bank

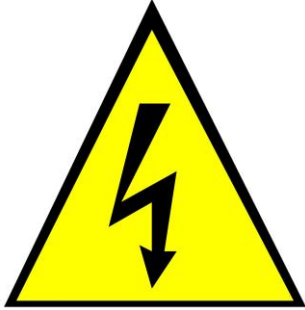

WARNING : SPARK HAZARD

Follow shutdown procedure before
connecting or disconnecting
any equipment.

Nominal BATTERY VOLTAGE - 120 Volts
Maximum FAULT CURRENT – 3,970 Amps

Battery Type: Sonnenschein SB6/330 A
(20 x 330 Ah 6V in series)

Battery Bank

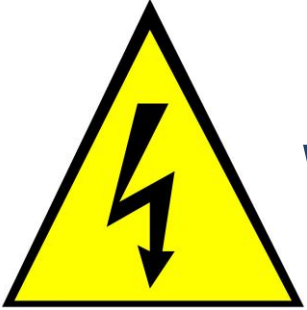

WARNING : SPARK HAZARD

Follow shutdown procedure before
connecting or disconnecting
any equipment.

Nominal BATTERY VOLTAGE - 120 Volts
Maximum FAULT CURRENT – 7,940 Amps

Battery Type: Sonnenschein SB6/330 A
(40 x 330 Ah 6V in series/parallel)